

Crestline® Dampening System

Installation Instructions

4 ROLL DAMPENER

Ryobi 3302M

Itek 3985

A.B. Dick 9985

ACCEL ®
Graphic Systems

GENERAL INFORMATION

ATTENTION CRESTLINE® DAMPENER OWNER!

Accel Graphic Systems provides parts and service through its authorized distributors and dealers. Therefore, all requests for parts and service should be directed to your local dealer.

The philosophy of Accel Graphic Systems is to continually improve all of its products. Written notices of changes and improvements are sent to Accel Graphic Systems' Dealers.

If the operating characteristics or the appearance of your product differs from those described in this manual, please contact your local Accel Graphic Systems Dealer for updated information and assistance.

Always update your dampener when improvements are made available, especially those related to safety.

YOUR AUTHORIZED CRESTLINE® DEALER IS:

**THE SERIAL NUMBER OF YOUR
CRESTLINE® DAMPENER(S) IS:**

SAFETY INFORMATION

FOR YOUR SAFETY, DO NOT DISENGAGE OR REMOVE ANY GUARDS FROM THE CRESTLINE® DAMPENER. THE DAMPENER CONTAINS SOME INWARD ROTATING ROLLER NIPS THAT CAN CAUSE INJURY IF LEFT UNGUARDED.

GENERAL INFORMATION

BASIC CONFIGURATION OF CRESTLINE® AND ROLLER PRESSURES

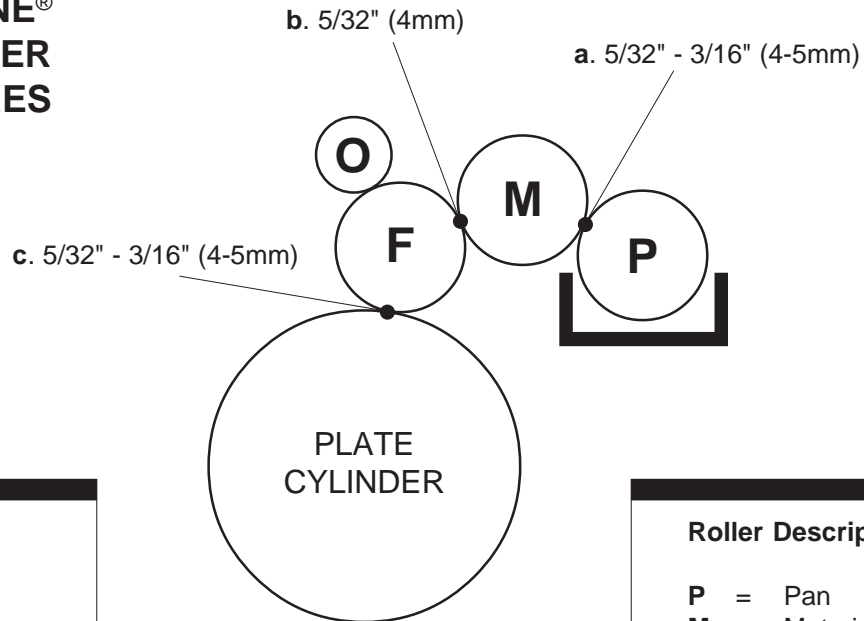

Adjustments

- a. Metering to Pan
- b. Metering to Form
- c. Form to Plate

Roller Description

- P = Pan
- M = Metering
- O = Oscillator
- F = Form

TERMINOLOGY

OPS = Operator's Side

NOPS = Non Operator's Side

TECHNICAL ASSISTANCE

For technical assistance during the installation, please contact:

ACCEL GRAPHIC SYSTEMS

11103 Indian Trail

Dallas, TX 75229

PHONE (972) 484-6808

FAX (800) 365-6510

E-MAIL accel@dallas.net

WEB SITE accelgraphicsystems.com

Crestline® is covered by U.S. Patents and Patents Pending

GENERAL INFORMATION

REQUIRED TOOLS FOR REMOVAL OF OLD DAMPENER AND INSTALLATION OF CRESTLINE®

1. Phillips Screwdriver
2. Standard Screwdriver
3. 1/8" & 3/32" Allen
4. 2.5, 3, 4, 5, & 6 mm Allens
5. 8, 10, 13, & 17 mm Wrenches
6. 7/16" Open End Wrench
7. Vise Grips
8. 4 mm Punch
9. Brass Drift
10. 1/8" Punch
11. Hammer

PRE-INSTALLATION INSTRUCTIONS

PRE-INSTALLATION PROCEDURES AND HOW TO PARALLEL THE DAMPENER.

1. Cut the ties holding the rollers and examine the rollers for gouges, scratches or nicks.
2. Check the box and parts boards to make sure all pieces are present and nothing has been damaged in shipment.
3. Check the dampener alignment by setting it on end on a flat surface such as a cutter bed. If dampener rocks, it needs to be realigned. Loosen the tie bar bolt and align the frames on the flat surface. Retighten bolt.

DISASSEMBLY

1

DAMPENER REMOVAL (IDENTICAL ON BOTH PRINTING UNITS)

Remove guards covering the plate cylinder on both printing units. Save screws for installation of new guards.

2

Remove operating handles and upper side covers from OPS & NOPS sides of the printing head.

3

Remove the small covers over the water control mechanism OPS & NOPS. On older model presses, remove the gray plate that indicated the clicks in ratchet system.

7

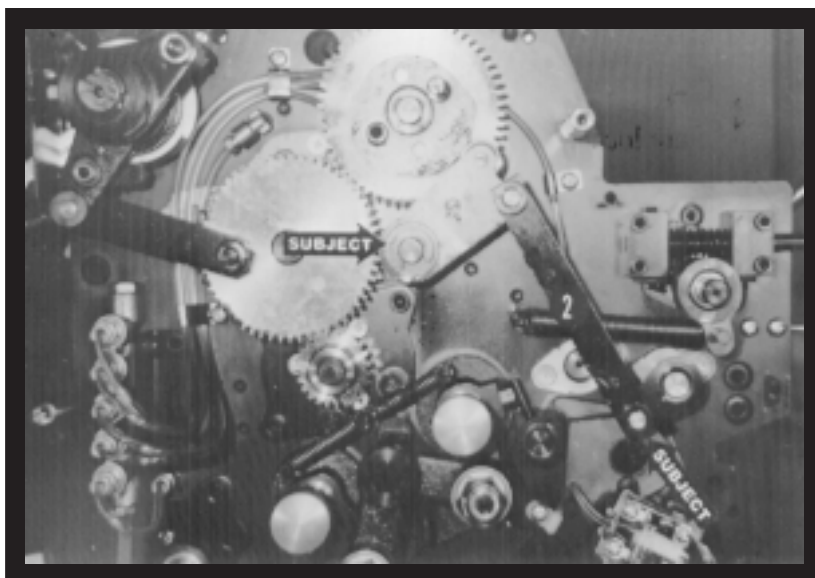
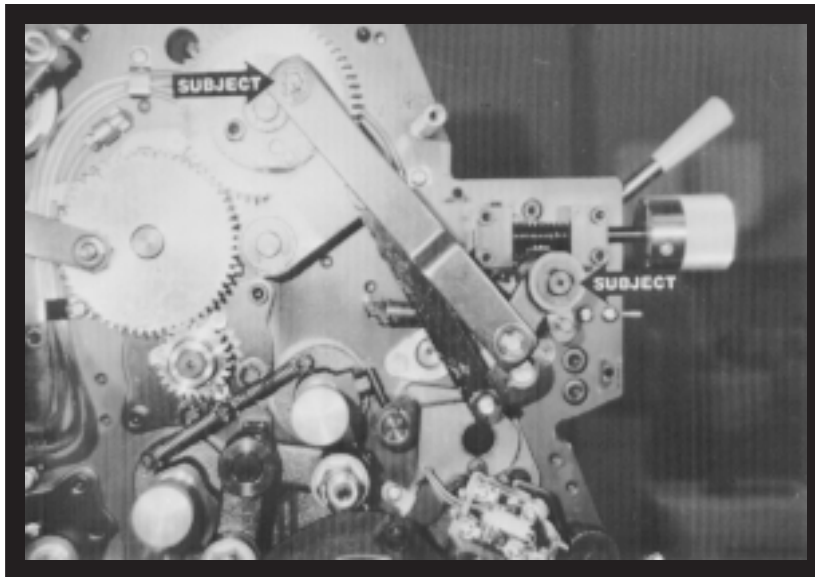

DISASSEMBLY

4

Remove the water tray and cloth covered rollers from both printing units.

5

Remove “E” clips and washers (subject arrows) from stud and pull off the assembly held by these parts. These are located at the OPS.

6

Remove the spring behind the arm (#2 not visible in picture). Remove the “E” clips and washers (subject arrows) and pull the assembly off. These are located OPS.

9

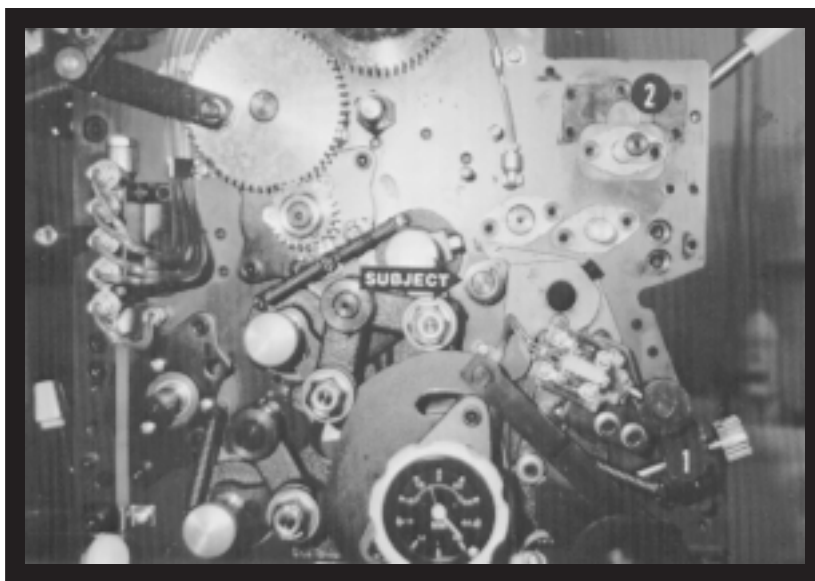
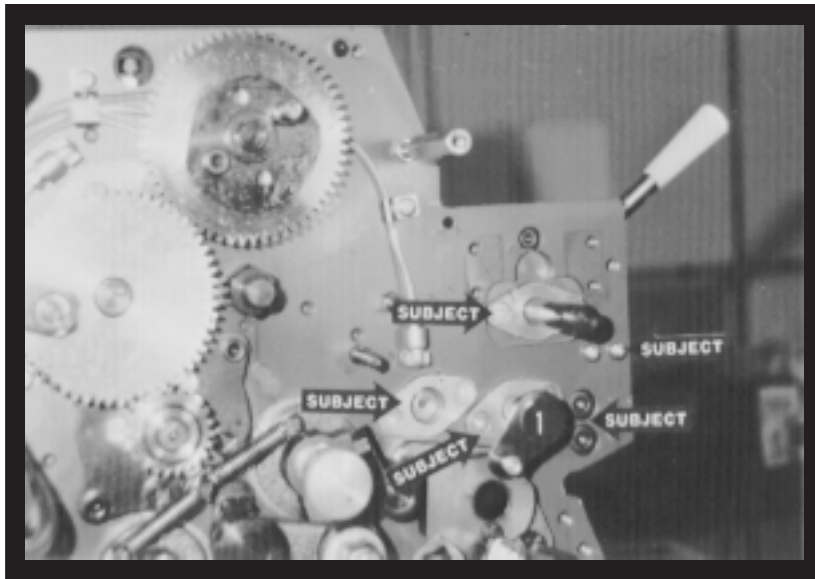
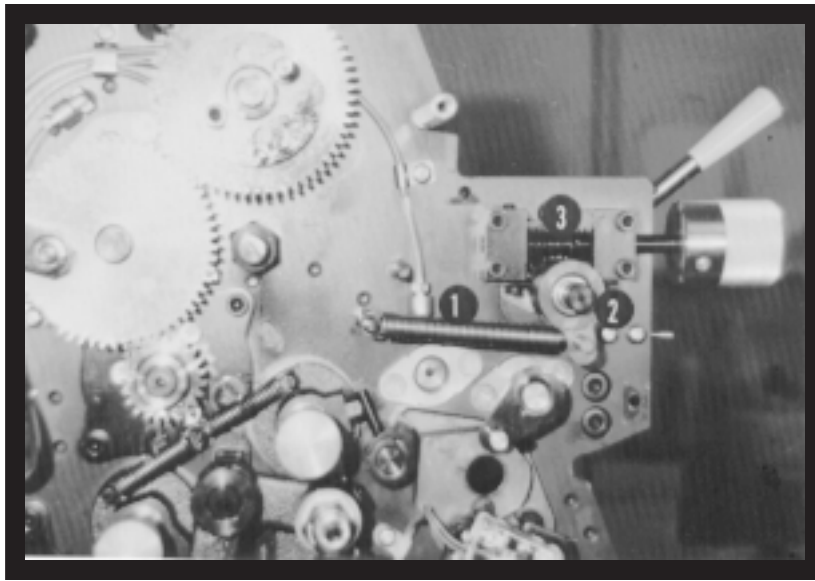

7

Remove the spring (#1), housing with clutch (#2), and infinite water control (#3, held on by 4 bolts) from the end of the water fountain roller shaft. (Older model 2 colors had an arm and ratchet assembly with a gear. Remove these pieces if the press does not have the infinite water control. The gear has a set screw in it that needs to be loosened before you can remove it.) These are located at the OPS.

8

Drive the pin out of the arm (#1) and remove it. Remove the screws near the subject arrows. The arrows on the left indicate the housings for the metal rollers and ductor. The upper arrow, on the right, is the water pan block, the lower arrow is the tie bar bolts. These are at the OPS. NOTE : A new tie bar will be installed in the press during the dampener installation.

9

Remove the long stop pin from the housing on the water form adjustment and screw block (#1) and the bolt from the wiper bar (#2). These are located at the OPS. (On older models, the bolt holding the wiper bar is at the NOPS.) Remove the wiper bar. NOTE : This picture has the parts already removed.

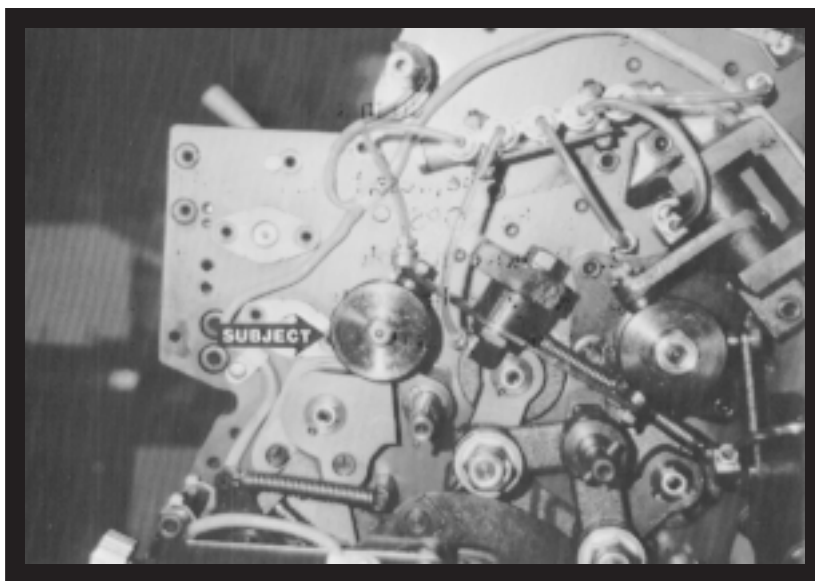
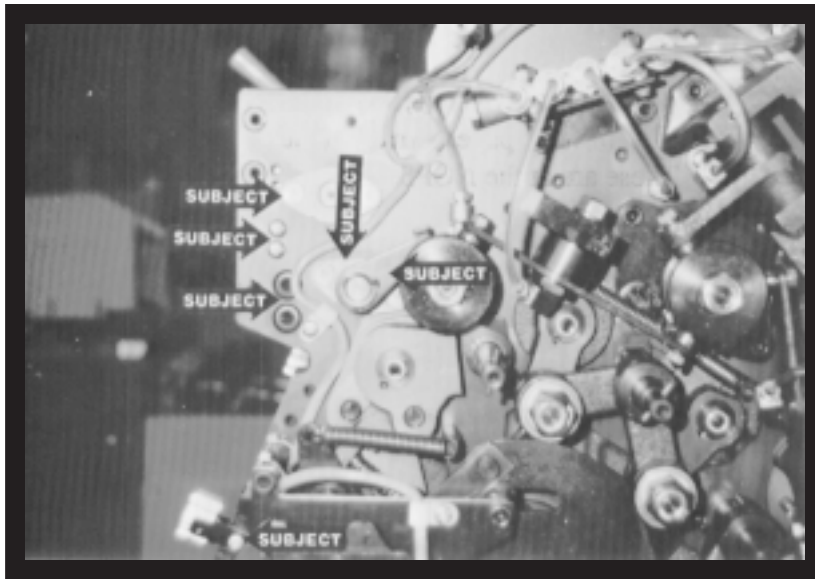
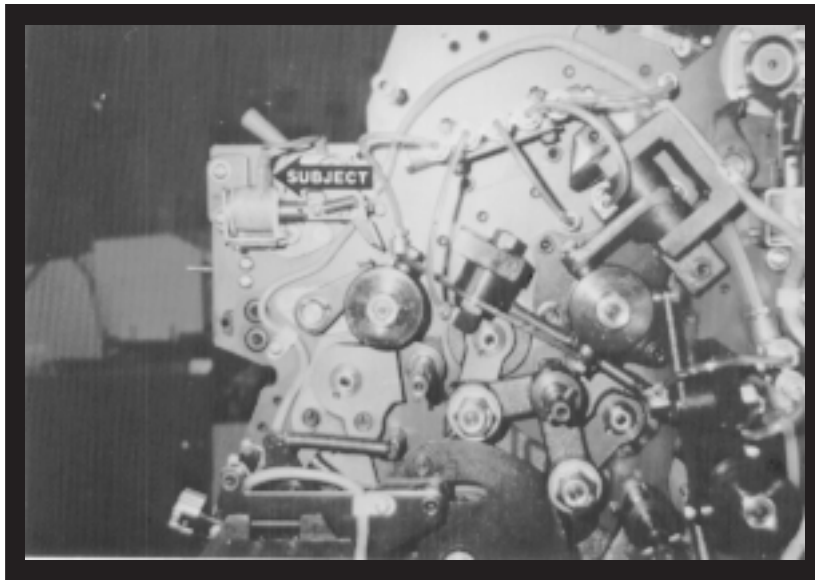

10

Unhook the wires from the solenoid at the NOPS (subject arrow) and remove it from the press. 3 screws hold the solenoid. Each screw has a washer and a spacer. Be sure these parts do not fall in the press.

11

Drive the pin out and remove the arm (subject arrows at far right.) Remove the screws near the other subject arrows except for the one at the very bottom of the page. (Arrow at the bottom of the page has only one screw.) These are at the NOPS.

12

Remove the bolt and spool from the end of the oscillator (subject arrow). The easiest way to do this is:

1. Rotate the press, by hand, until the oscillator has moved all the way to the NOPS.
2. Remove the bolt and lock washer from the end of the oscillator.
3. Remove the oscillator bushing at the OPS and slide the oscillator roller by hand to the OPS. The spool will come off.

13

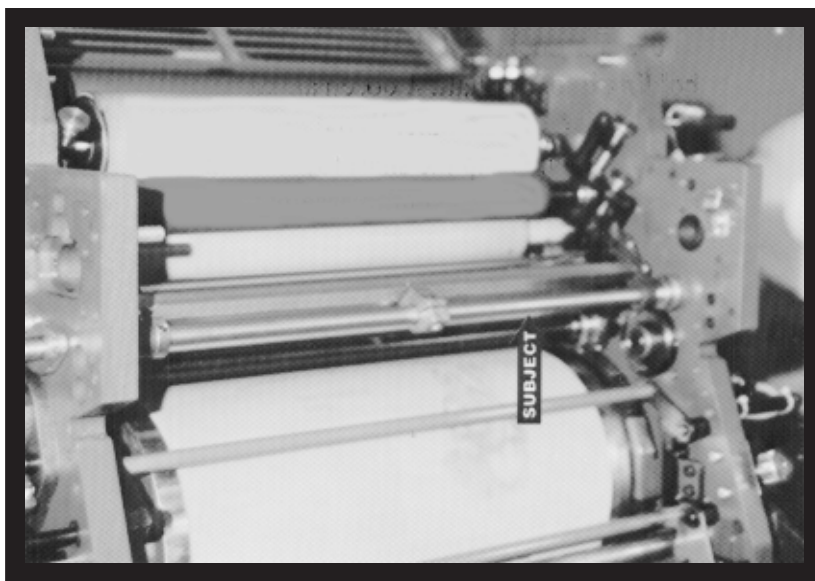
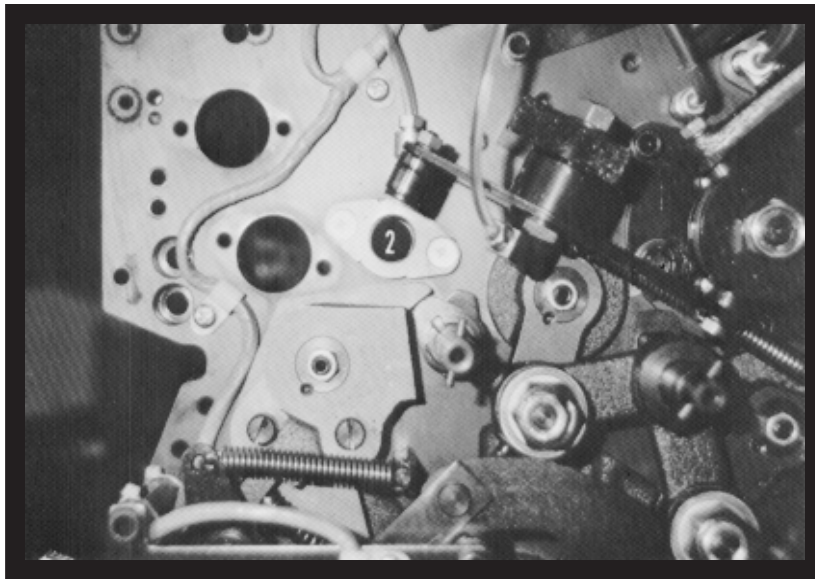
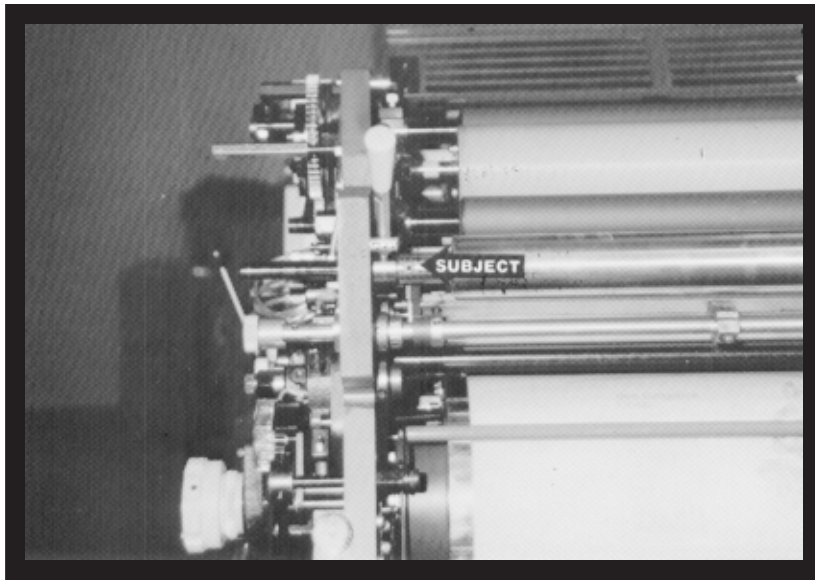

13

Remove the cap screw (subject arrow) holding the two pieces of the water fountain roller together. Remove the bushings from the side frame holding the roller, slide the two pieces apart, and remove the pan roller and extension from the press. (Older model 2 colors have a single piece fountain roller.)

14

Remove the 2 screws and bushing (near #2) for the oscillator at the NOPS. Slide the oscillator roller out of the press.

15

The water ductor mechanism (subject arrow) has a series of set screws holding it to the shaft. Loosen all the set screws, including the one in the brass collar in the middle. Remove the bushings holding the shaft in the side frames. Gently tap the shaft towards the OPS until it clears the inside of the press frame. The entire assembly can be removed.

15

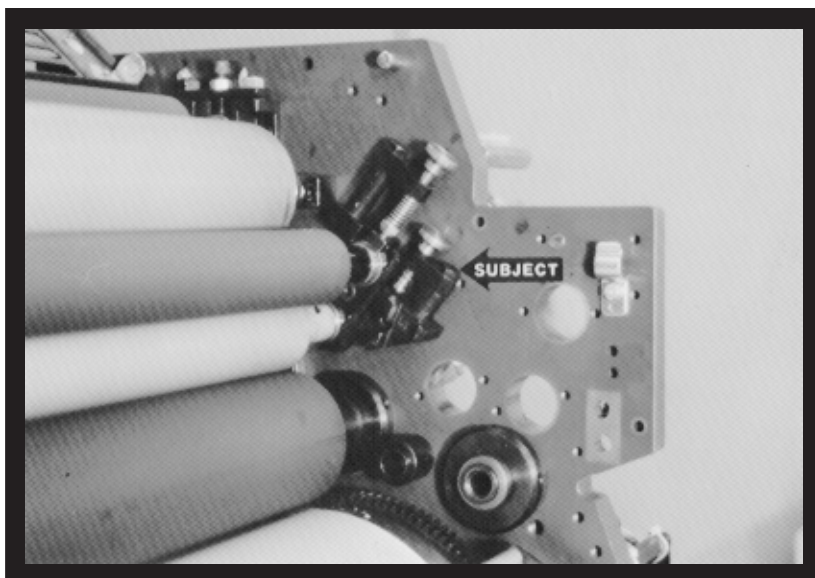
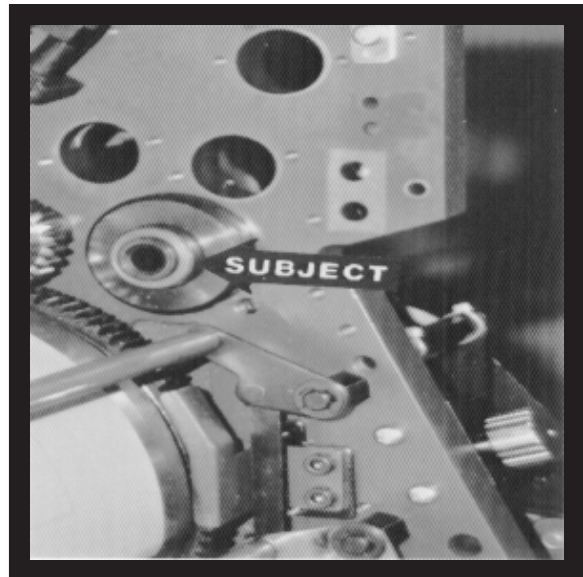
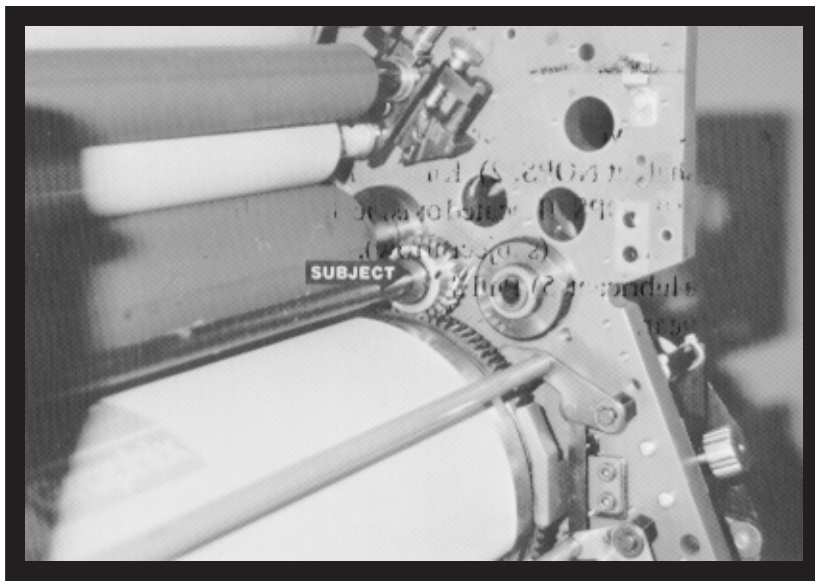

DISASSEMBLY

16

Remove the water form night latch as follows : 1) Put the handle on the shaft at NOPS. 2) Knock the pin out and remove the collar on the shaft at the OPS. (Located outside the side frame.) 3) Loosen the two set screws in the collar (subject arrow). 4) Clean the shaft thoroughly and spray with a lubricant. 5) Pull the shaft towards the NOPS to remove shaft, collar and gear.

17

Loosen set screw (subject arrow) and remove set screw and lock nut (#1). Gently tap inner ring until it is flush with the middle ring. Tighten set screw and replace set screw and lock nut. THIS IS ONLY DONE AT NOPS.

18

Remove the bolt and spring loaded assembly (subject arrow) at OPS & NOPS.

17



19

Remove the studs (#2) from inside the press frame. There is one stud in the first printing unit and 3 in the second printing unit.

YOU ARE NOW READY TO INSTALL CRESTLINE®.

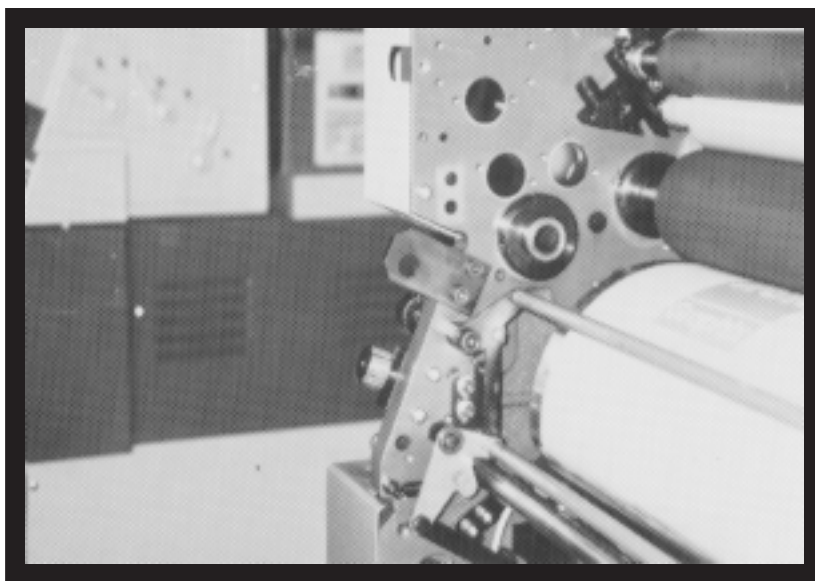
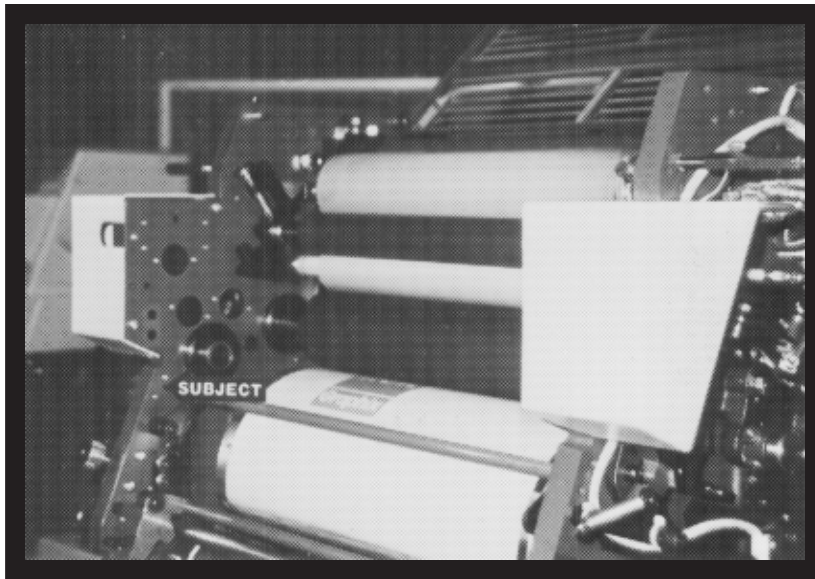
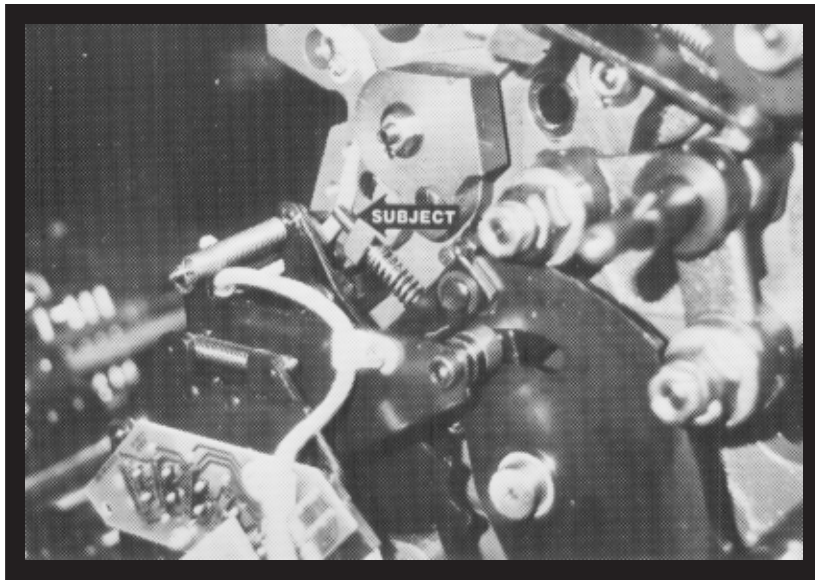

INSTALLATION

1

Tighten screw (subject arrow) until it is flush with cast metal arm that it is threaded through. This tightens the spring and prevents the entire housing from moving. Screws are located at OPS & NOPS.

2

Reinstall small side covers. On older presses, also install gray plates taken off with the small side covers. (Photo shown with covers on.) Also, note the two holes below the cover (subject arrow). These holes are used in step 3.

3

Install the mounting blocks as shown. Push down on the block when tightening. The bolts are threaded into the holes mentioned in the previous step.

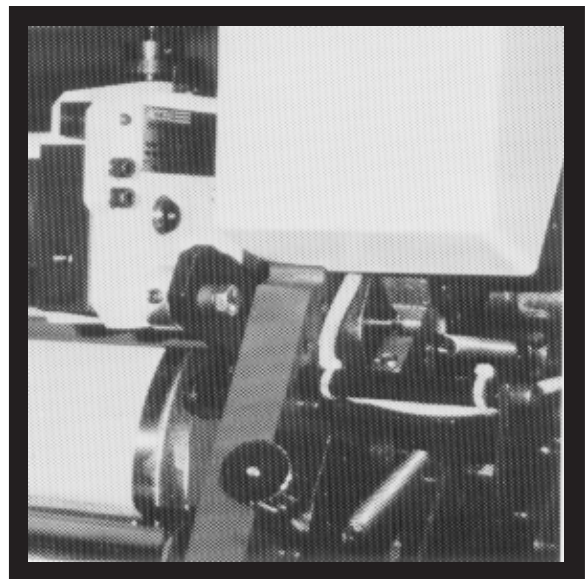
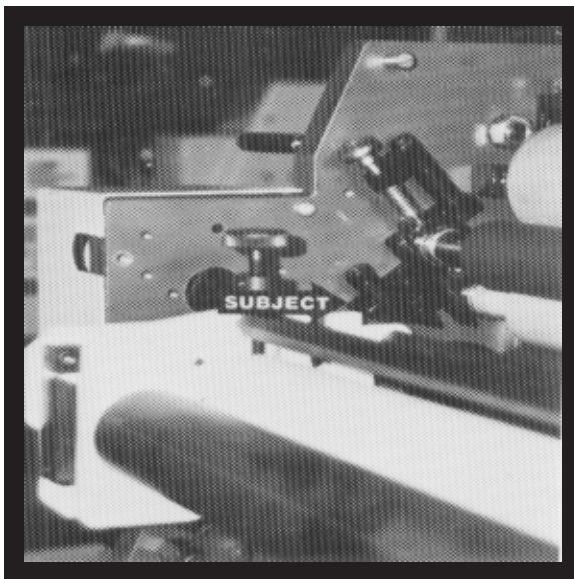
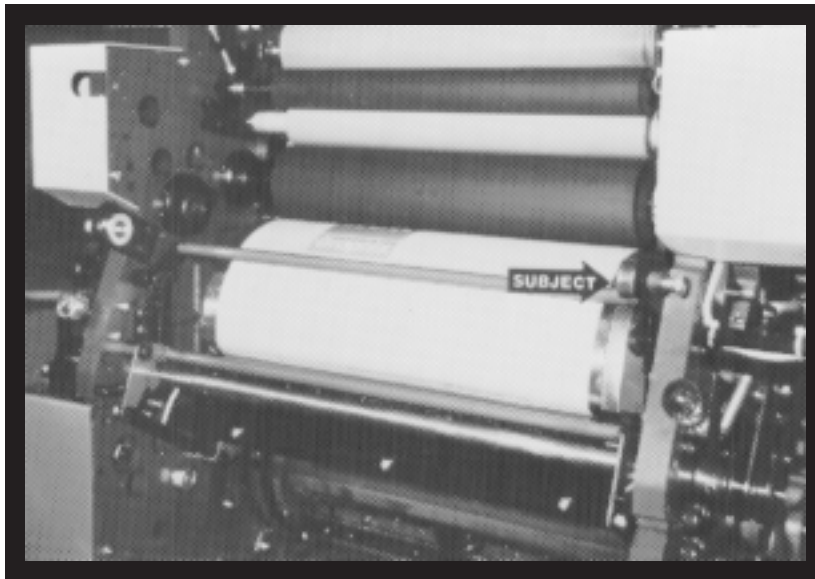
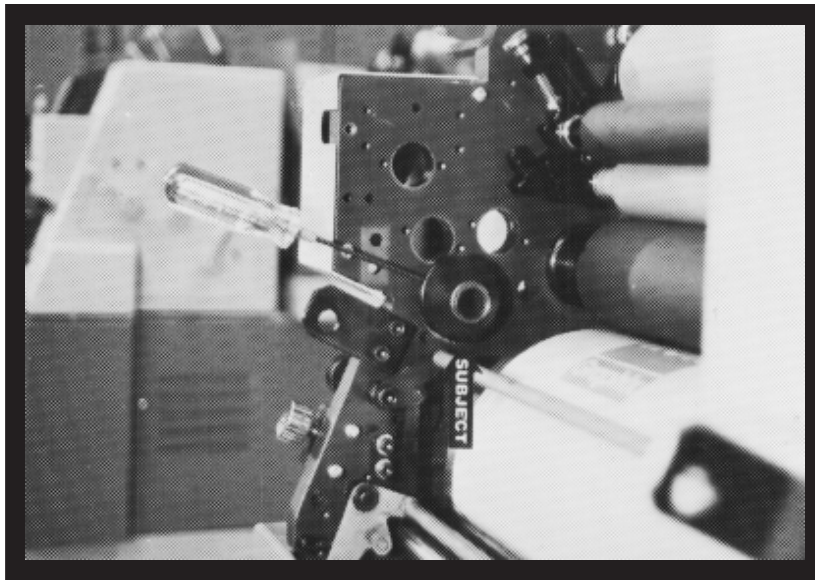

4

Install the eccentric cams over the ring where the water form shaft from the old dampener was positioned. Each eccentric has two set screws. Only install one set screw at this time. The second one is installed later. Position the cam so the allen wrench is parallel to the mounting block.

5

Place the bolts, mounting spools, and set collars into the mounting blocks as shown (subject arrow). The set collar should be flush against the mounting block and the spool should not extend past the set collar.

6

Slide the front edge of the dampener underneath the casting (subject arrow). Making sure the gears mesh, align the threaded hole in the back of the dampener with the spool installed in the previous step. Place the bolt through the spool and thread it into the hole in the dampener frame. Tighten until the bolt does not turn. After tightening the bolt at both OPS & NOPS, move the set collar (located between dampener frame and mounting block) against the mounting block and tighten. Now, snug up the bolt.

CAUTION : Do not overtighten the mounting bolts. This may cause the dampener to be cocked and create gear noise.

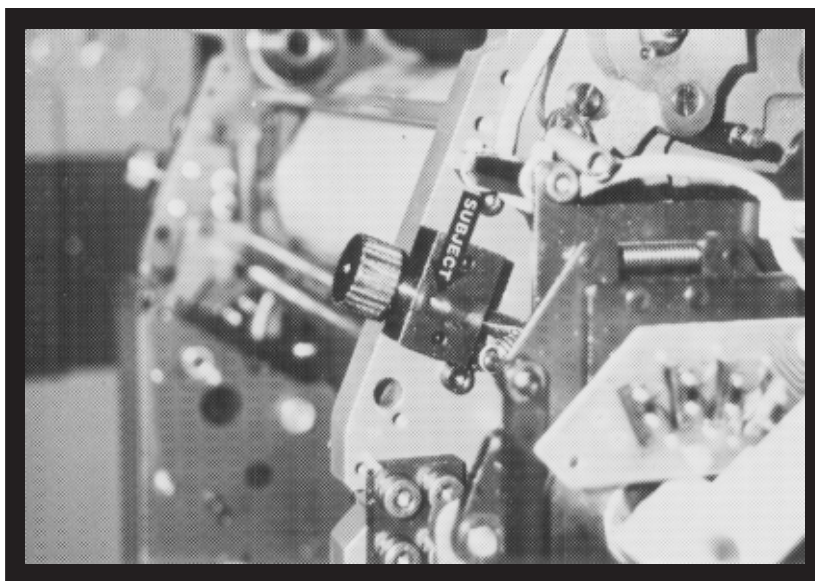
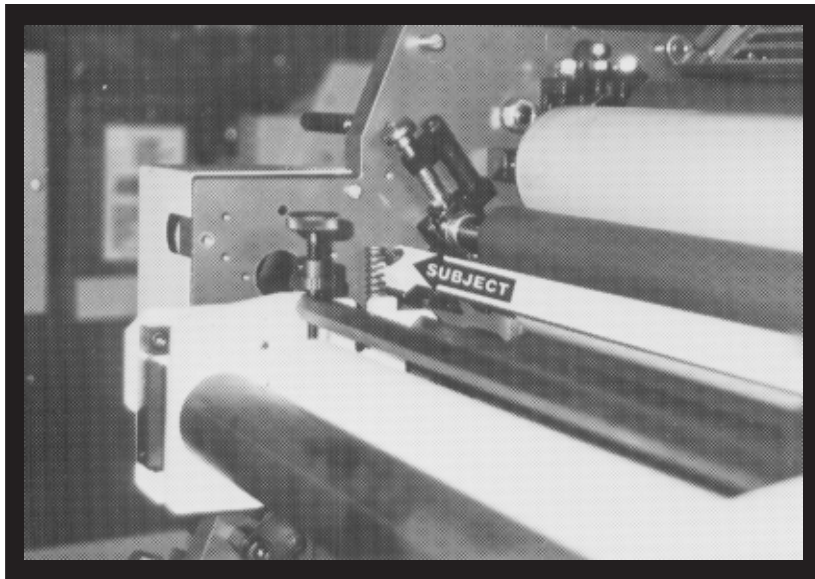
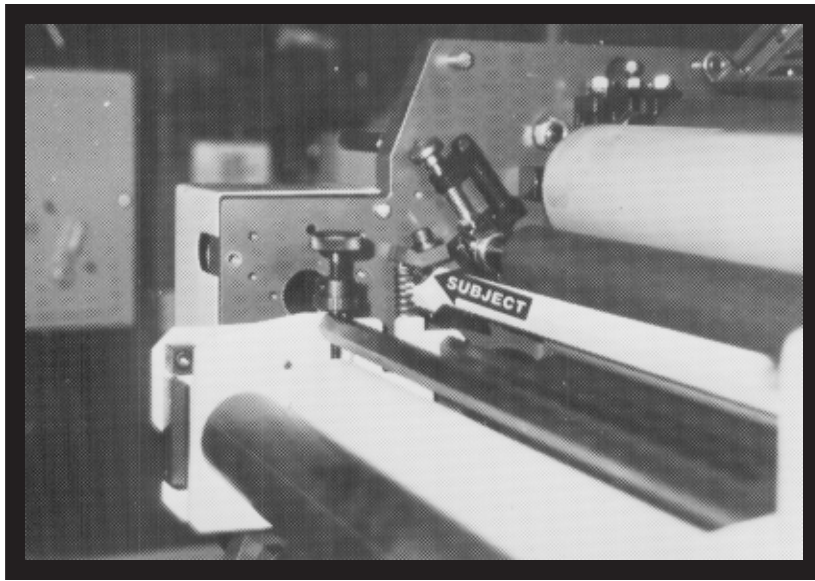

INSTALLATION

7

Install the tie bar and compression spring at OPS & NOPS as shown (subject arrow). The tie bar rests over the post.

8

Install the compression clip, washer, and bolt as shown (subject arrow). Washer goes between bolt head and clip with pin in the clip in the spring. The cut off corner of the clip goes towards the center of the press. Tighten the bolt thoroughly.

9

Install the small, brass tipped set screw in the threaded hole of the water form adjusting screw block (subject arrow). DO NOT TIGHTEN AT THIS TIME.

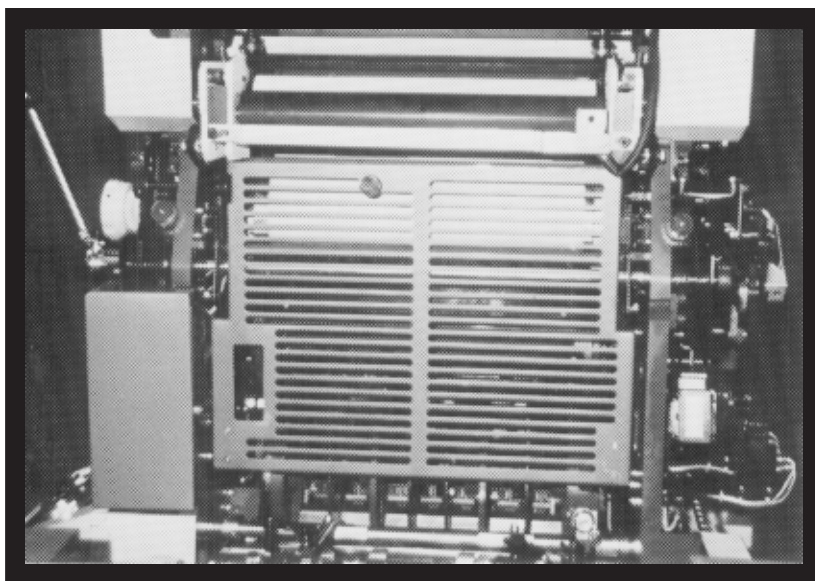
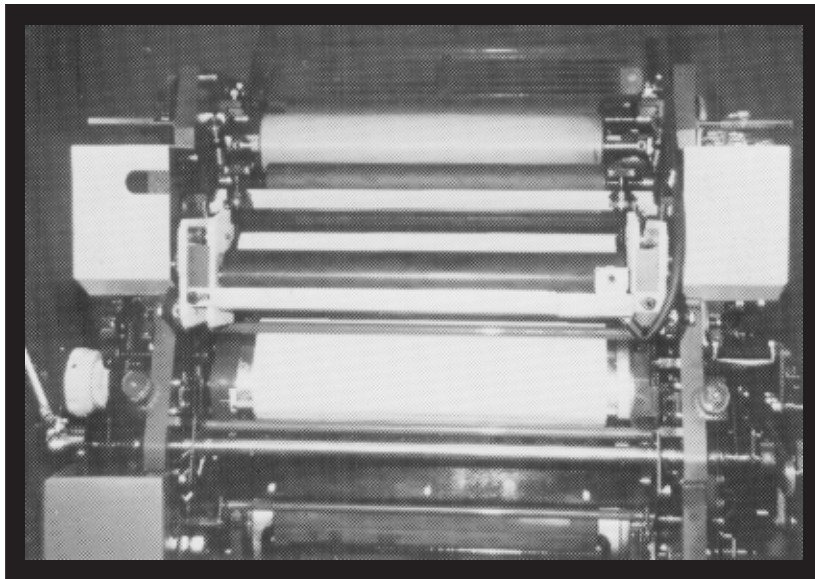
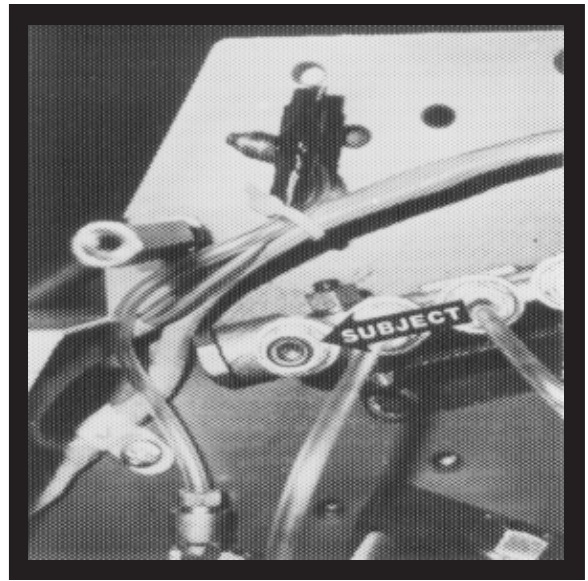

10

Close off the upper oil lines in the central lubrication system with the pipe plugs and zip ties (subject arrows). OPS side is at left, NOPS at right. NOTE : The solenoid wires are also tied off with the oil line at NOPS. Be sure to wrap them in electrical tape before tying them off.

11

Mount the water pan as shown. Check to make sure the front edge of the pan does not touch the metering/transfer roller of the dampener. If it appears like the roller is going to touch the pan, loosen the pan block bolts (outside of dampener frame) and swing the blocks towards the feed end of the press to lower the front edge of the pan. Use the older water clip to hold the water hose.

12

Install the largest guard on the first printing unit, using the hinges and handle from the previous guard. Install the smallest guard on the second printing unit on the existing hinges.

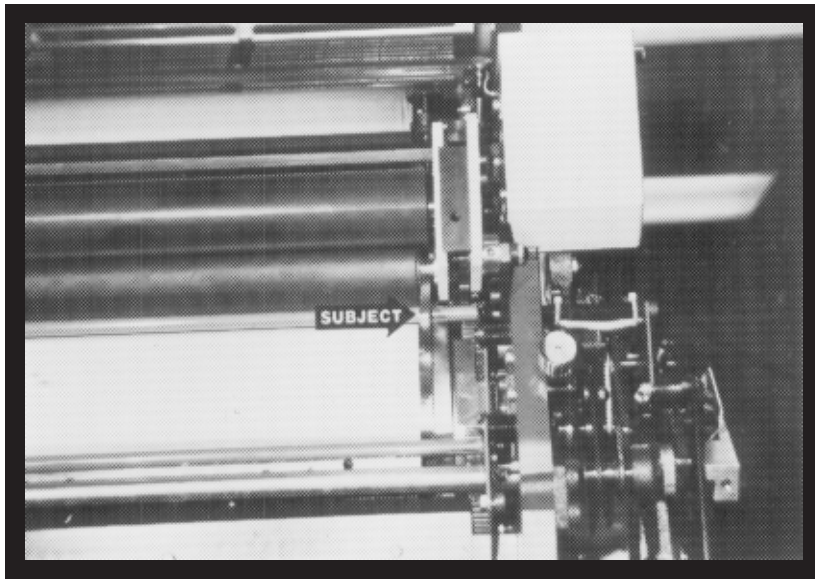
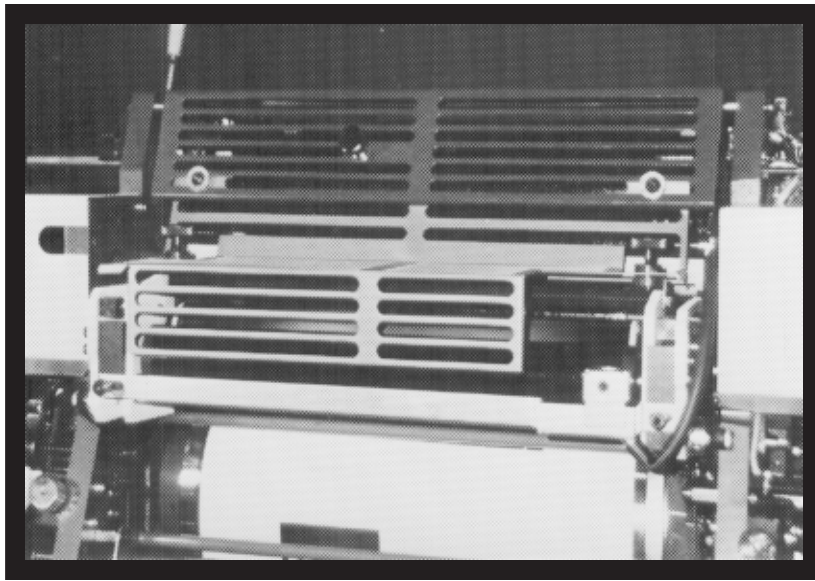

13

Install the guard over the dampener as shown.

14

Adjust the gear depth of the dampener to the plate cylinder as follows :

1. Place the thick end of the gauge tool between the water form roller shaft and the chrome surface of the plate cylinder. (Gauge shown by subject arrow).
2. Using a long, 1/8" allen wrench, loosen the set screw in the eccentric cam and rotate the cam down until the shaft holds the tool firmly in place. Tighten the set screw. NOTE: Tightening the set screw raises the cam slightly, loosening the gauge. This does not adversely effect the gear depth.
3. Use this procedure at OPS & NOPS of each printing head. When finished, put the second set screw in the eccentric cam.

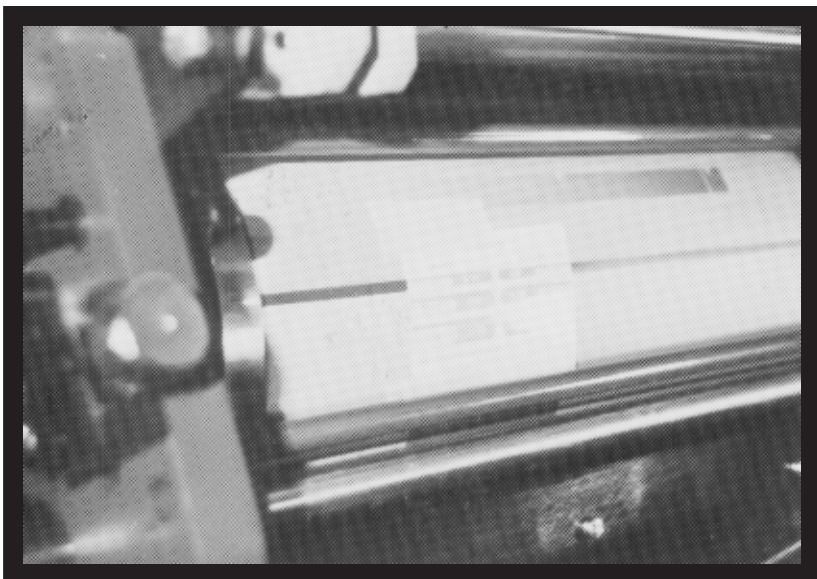

FINAL ADJUSTMENTS

1

Mount a metal plate to both plate cylinders.

2

Dab a small amount of ink on the dampener oscillator and run press at 3000iph to distribute it evenly on all rollers.

3

Drop the dampener to the plate using the operation handle. The dampener drops when moving the handle to the first position (same as with the molletons). An even $5/32$ " stripe should be used from water form roller to the plate. Turn the water from adjusting knobs (used to adjust pressure of molleton roller to plate) to vary the stripe. Turning the knobs makes a thinner stripe. After getting an even $5/32$ " across the plate, lock the knobs in position using the small set screws installed in step 9 of the dampener installation procedures.

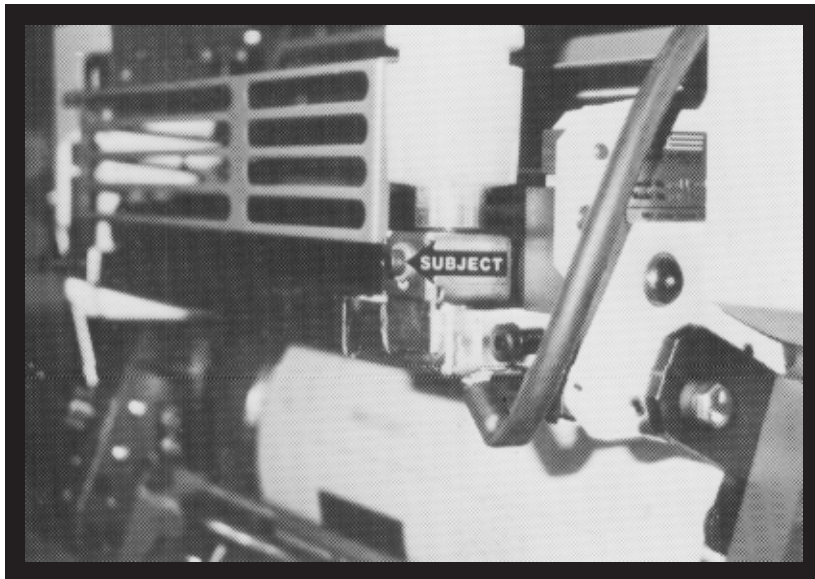
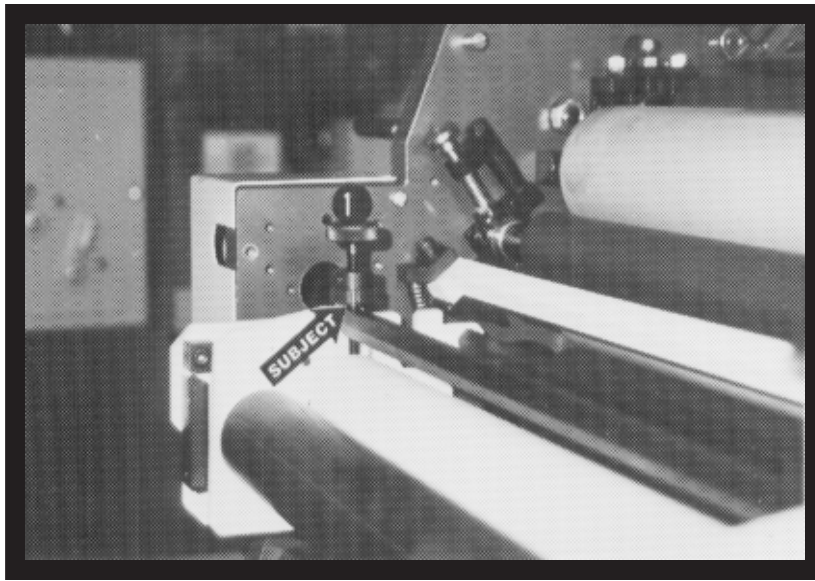

FINAL ADJUSTMENTS

4

Set metering pressure between the metering and pan rollers as follows :

1. Spin the ratchet gear (subject arrow) down until it stops against the cross bar.
 2. Adjust the knurled knob down until an even $5/32$ " stripe is obtained between the pan and metering rollers. Always check the stripe on the pan roller.
 3. Lock the ratchet gear to the knurled knob by tightening the two set screws in the ratchet gear. (They are brass tipped and should not damage the threads on the knurled knob).
-

5

Place the water bottle in the bracket with some water in it. Adjust the water height by raising or lowering the bracket with the bolt (subject arrow). The water should be about $1/2$ to $3/4$ the way up the side of the water pan.

BASIC OPERATION

START OF DAY

- A. Make sure the oscillator, lower intermediate and metering rollers are in place.
- B. Spin knurled knobs until the shoulder on the ratchet stops against the stud bar.
- C. Place water bottle in bracket.

NOTE: Accel recommends using the proper fountain solution for the plate material being run on the press. A good acid/gum etch should be used with metal plates.

- D. Mount plate to cylinder. Wipe down all plates before running. Pre-ink the Crestline® dampener before running the plates with an extremely light coverage of ink. Dab the ink on the oscillator only.

RUNNING DURING THE DAY

- A. In general, the Crestline® Dampener should not have to be adjusted from job to job. The form roller setting should never be changed unless it has deviated from the factory specification of 5/32" to the plate.
- B. Adjustments to the amount of water fed to the plate are made by the knurled knobs that apply pressure to the metering roller. The dampener has been set up for minimum water. To increase the water to the plate, turn the knurled knobs counter clockwise 1 or 2 clicks at a time. This opens the gap between the metering and pan rollers and allows more water to the plate.
- C. In general, more water will only be required when going from a metal plate to an electrostatic or Silvermaster-type plate.

CLEANING & MAINTENANCE

WASH UPS DURING THE DAY

1. Remove bottle and drain the excess water from the pan.
2. Mount a metal plate to the press.
3. Turn on the press and squirt a small amount of press wash on the ink rollers.
4. Drop both the dampener and ink forms to the plate. It will be necessary to drop the forms manually rather than by the single lever. In general, the dampener will pick up enough roller wash off the plate to clean itself. Apply wash directly to the dampener only when necessary.
5. Use wash up attachment as normal. The plate cylinder is being used as a bridge between the dampener and inker. Solution transfers from the dampener to the plate, plate to inker, and inker to wash up attachment.
6. Remove water pan and clean any solution left in it.
7. Be sure to wipe excess clean up solution from the ends of the dampener metering and pan rollers.

END OF THE DAY

1. Wash up dampener. Pay close attention to cleaning the ends of the pan and metering rollers that extend past the form rollers.
2. Spin the knurled knobs up until the metering roller can be removed.
3. Remove metering roller and wipe down thoroughly to remove any excess wash that may be on the roller.

CLEANING & MAINTENANCE

DEGLAZING THE DAMPENER

Periodic deglazing of water-soluble contaminants will be necessary with the Crestline®. Typically, once every 2-3 weeks will be sufficient, unless you are running electrostatic plates on a daily basis whereas deglazing should be performed weekly. A 50/50 solution of household ammonia and hot water can be used for deglazing purposes. If you prefer a commercially available deglazer, avoid those containing pumice or gritty substances. Always follow deglazing with straight water and then roller wash. Accel offers a product called **COMPOUND X** that we recommend for deglazing our system. Contact your dealer or Accel for more information.

OILING AND GREASING THE DAMPENER

- A. Place a small amount of grease on the gears once a month.
- B. Inject grease into the oscillator grease fitting once a month.

CLEANING & MAINTENANCE

CRESTLINE® CLEANING & MAINTENANCE CHART

	Daily	Weekly	Bi-Weekly	Monthly
Wash Rollers	✓			
Deglaze Rollers				
Metal Plate Users			✓	
Silvermaster Plate Users			✓	
Electrostatic Plate Users		✓		
Grease Gears				✓
Inspect Ball Bearings				✓
Check Roller Pressures				✓
Check Roller Surfaces				✓

RYOBI 4-ROLL OPS

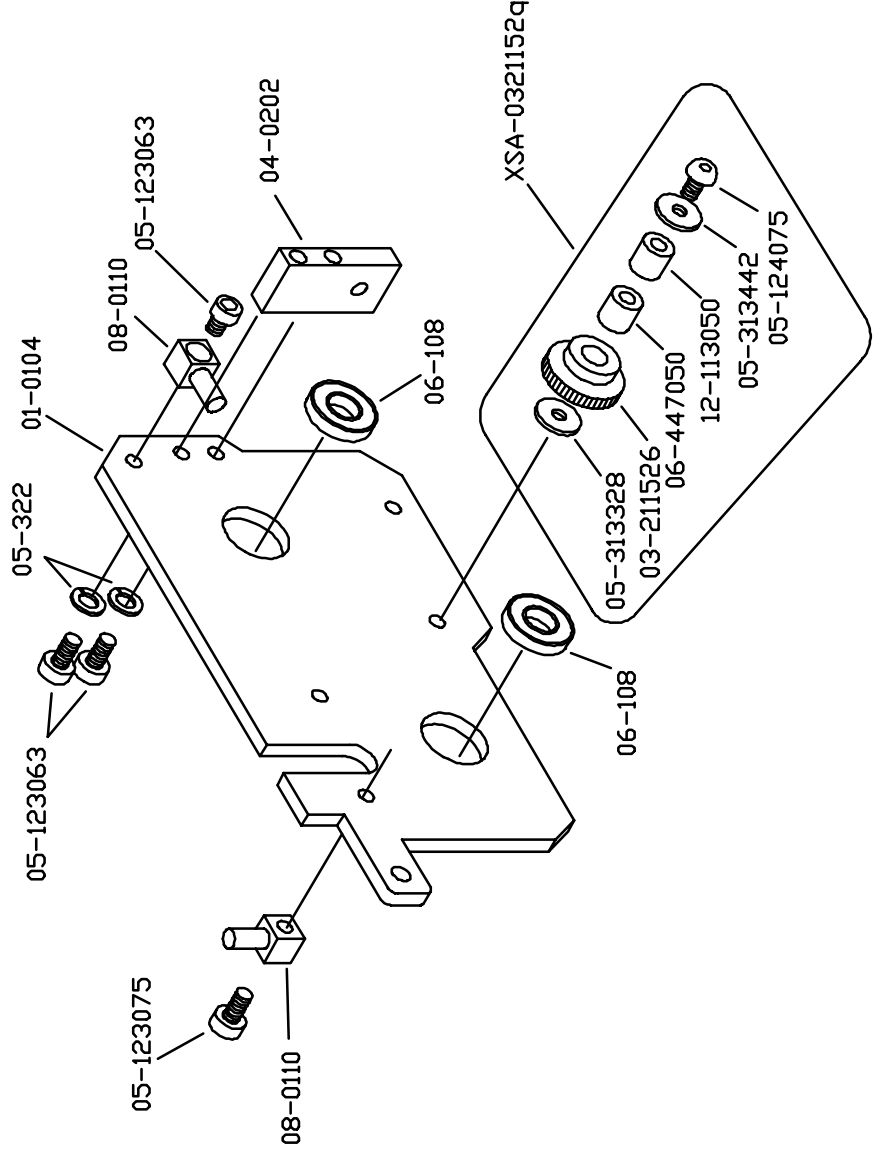

RYOBI 4-ROLL NOPS

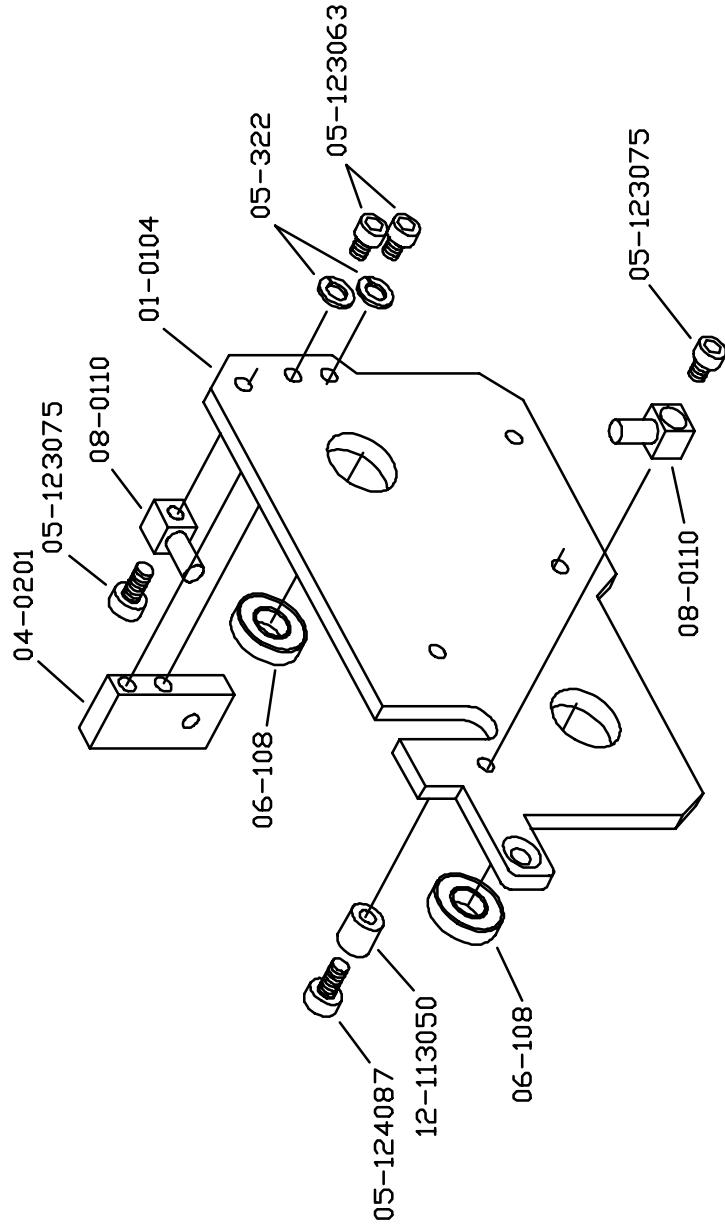

RYOBI 4-ROLL

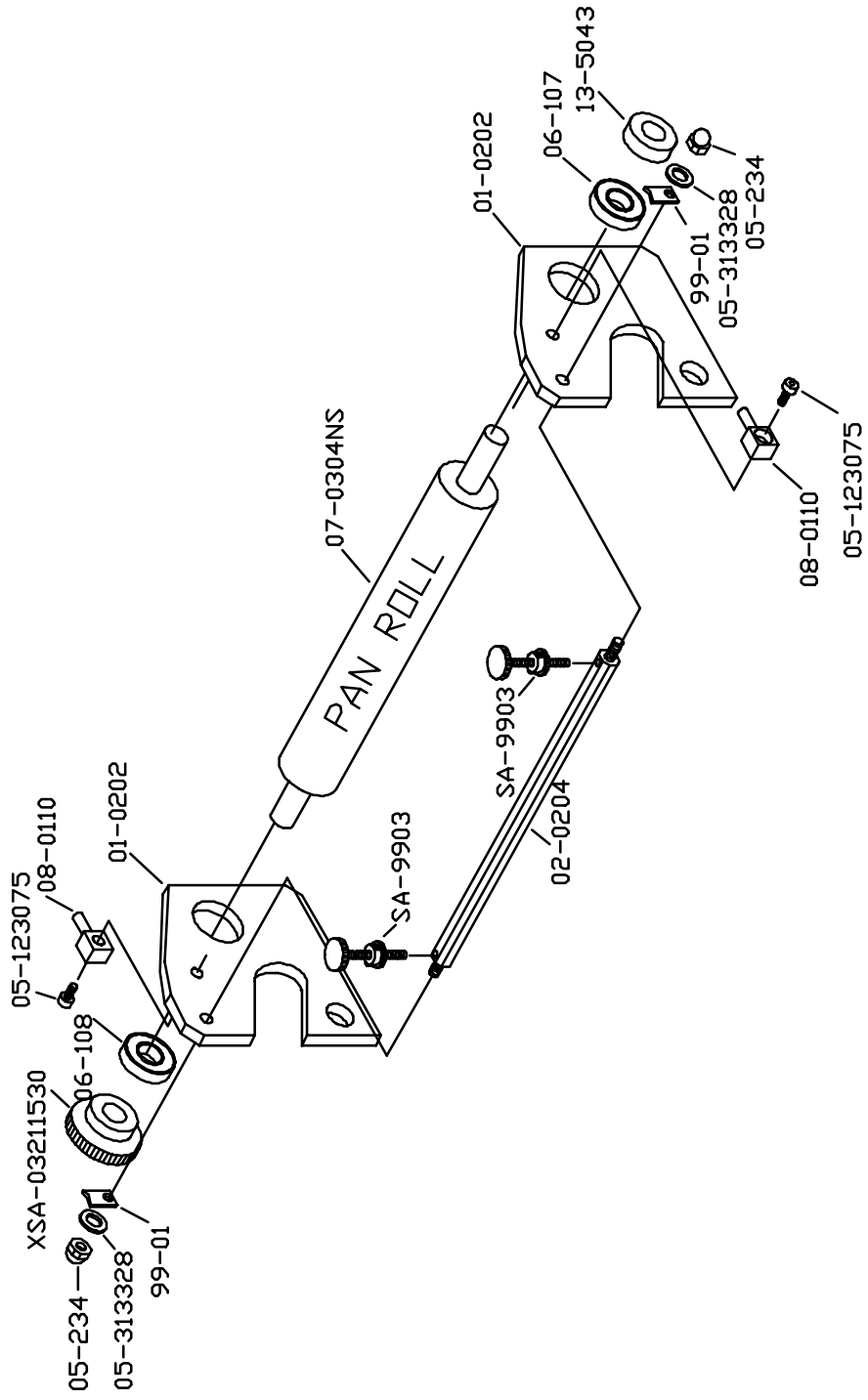

RYOBI 4-ROLL

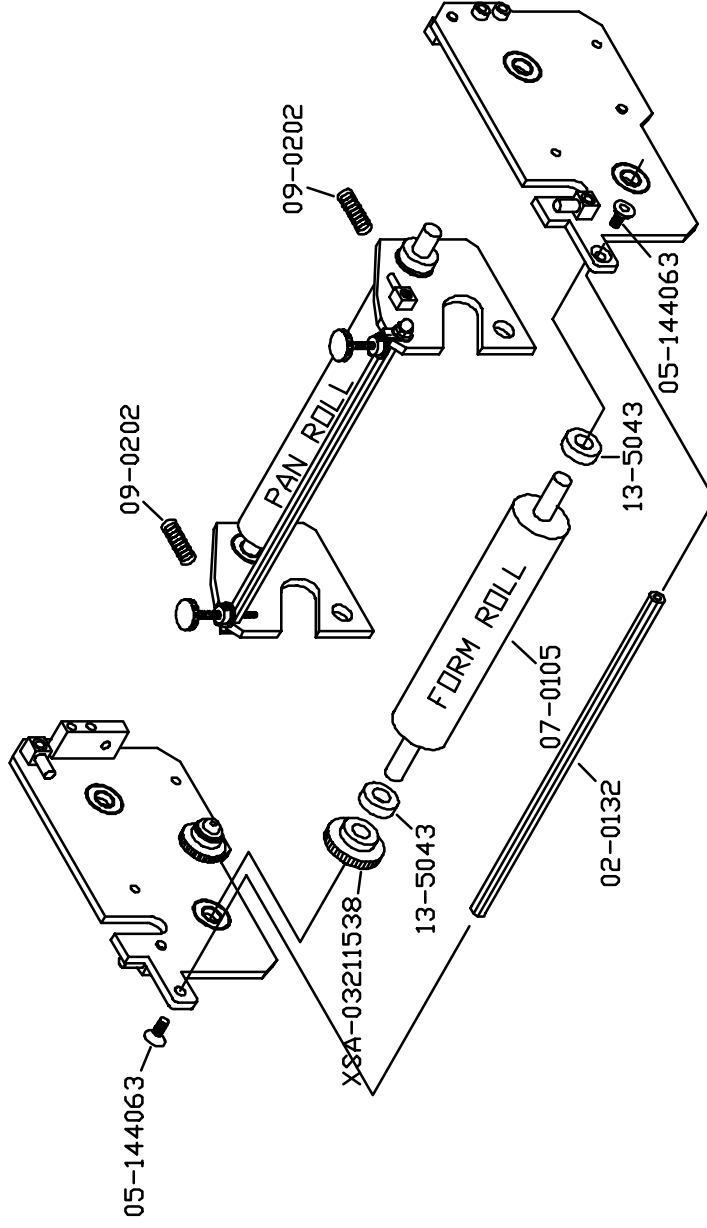

RY4R4, 2-93

RYOBI 4-ROLL

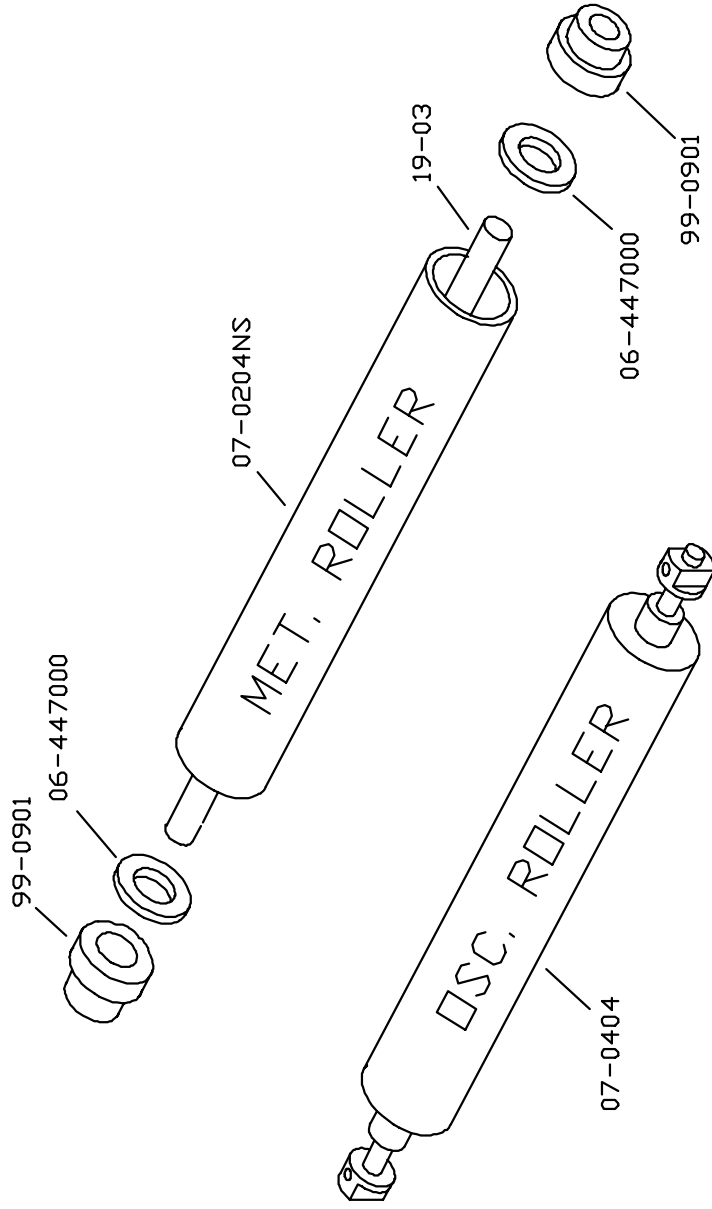

RYOBI 4-ROLL

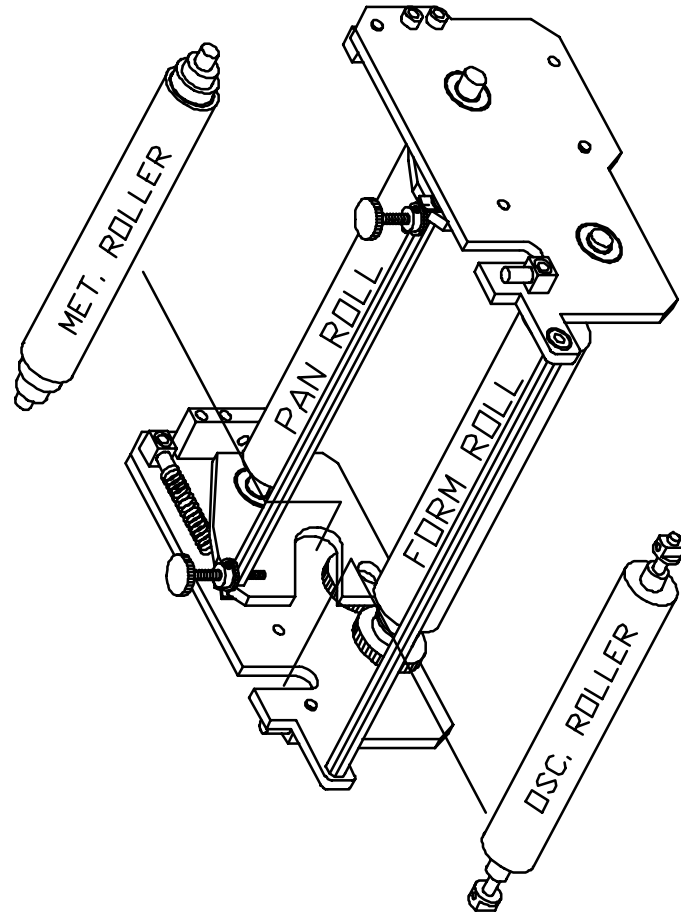

RY4R6, 2-93

RYOBI 4-ROLL

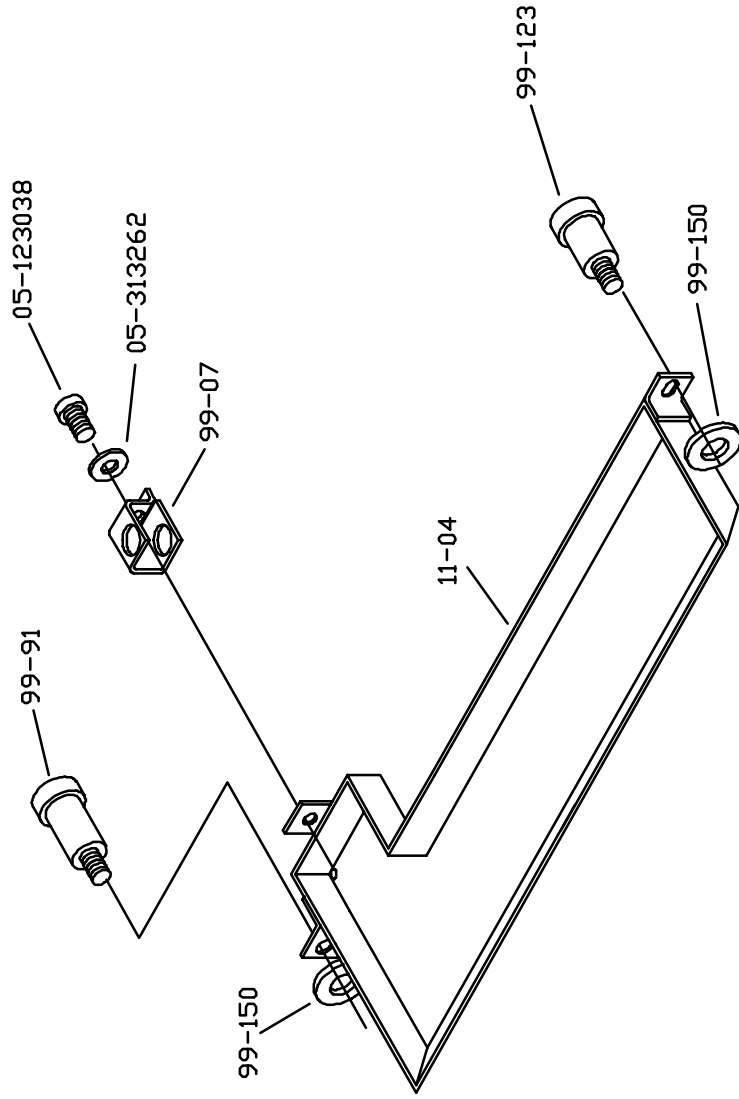

ACCEL  [®]
Graphic Systems

11103 Indian Trail, Dallas, TX 75229 Phone 972-484-6808, Fax 800-365-6510
E-Mail accel@dallas.net, Web Site www.accelgraphicsystems.com