

# **Crestline<sup>®</sup> Dampening Systems**

## **Installation Instructions**

**A.B. Dick 8800 Series**

**9800 Series**

**9900 Series**



*A Pamarco Technologies Inc. Company*

X88-21  
01/2001  
Rev-A

# GENERAL INFORMATION

## **ATTENTION CRESTLINE® DAMPENER OWNER!**

Accel Graphic Systems provides parts and service through its authorized distributors and dealers. Therefore, all requests for parts and service should be directed to your local dealer.

The philosophy of Accel Graphic Systems is to continually improve all of its products. Written notices of changes and improvements are sent to Accel Graphic Systems' Dealers.

If the operating characteristics or the appearance of your product differs from those described in this manual, please contact your local Accel Graphic Systems Dealer for updated information and assistance.

Always update your dampener when improvements are made available, especially those related to safety.

**YOUR AUTHORIZED CRESTLINE® DEALER IS:**

---

---

---

---

**THE SERIAL NUMBER OF YOUR  
CRESTLINE® DAMPENER(S) IS:**

---

---

## **SAFETY INFORMATION**

**FOR YOUR SAFETY, DO NOT DISENGAGE OR REMOVE ANY GUARDS FROM THE CRESTLINE® DAMPENER. THE DAMPENER CONTAINS SOME INWARD ROTATING ROLLER NIPS THAT CAN CAUSE INJURY IF LEFT UNGUARDED.**

# GENERAL INFORMATION

## BASIC CONFIGURATION OF CRESTLINE®

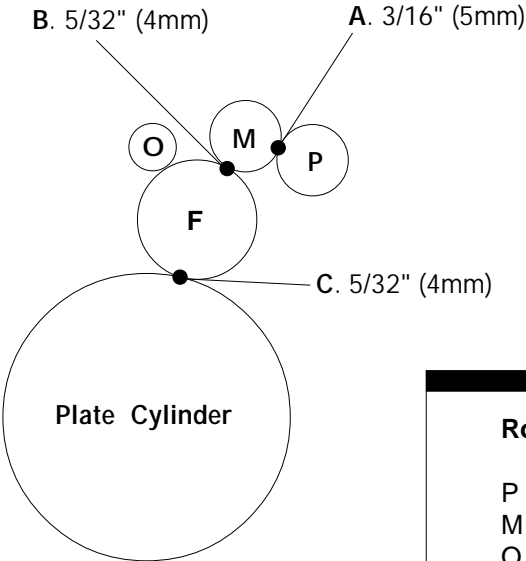

Adjustments
A. Metering to Pan
B. Form to Metering
C. Form to Plate

Roller Description
P = Pan
M = Metering
O = Oscillator
F = Form

TERMINOLOGY
OPS = Operator's Side
NOPS = Non Operator's Side

## TECHNICAL ASSISTANCE

For technical assistance during the installation, please contact:

**ACCEL GRAPHIC SYSTEMS**  
11103 Indian Trail  
Dallas, TX 75229  
(972) 484-6808  
FAX (800) 365-6510  
E-MAIL [accel@dallas.net](mailto:accel@dallas.net)  
WEB SITE [www.accelgraphicsystems.com](http://www.accelgraphicsystems.com)

Crestline® is covered by U.S. Patents and Patents Pending

# GENERAL INFORMATION

- REQUIRED TOOLS**
1. Phillips Screwdriver
  2. Standard Screwdriver
  3. 3/32" Allen Wrench
  4. 1/8" Allen Wrench
  5. 5/32" Allen Wrench
  6. 7/16" Open End Wrench
  7. 1/2" Open End Wrench
  8. 3/8" Open End Wrench
  9. Spring Hook Tool
  10. 3/32" Punch
  11. Hammer

# PRE-INSTALLATION INSTRUCTIONS

## PRE-INSTALLATION PROCEDURES AND HOW TO PARALLEL THE DAMPENER.

1. Cut the ties holding the rollers and examine the rollers for gouges, scratches or nicks.
2. Check the box and parts boards to make sure all pieces are present and nothing has been damaged in shipment.
3. Check the dampener alignment by setting it on end on a flat surface such as a cutter bed. If dampener rocks, it needs to be realigned. Loosen the tie bar bolt and align the frames on the flat surface. Retighten bolt.

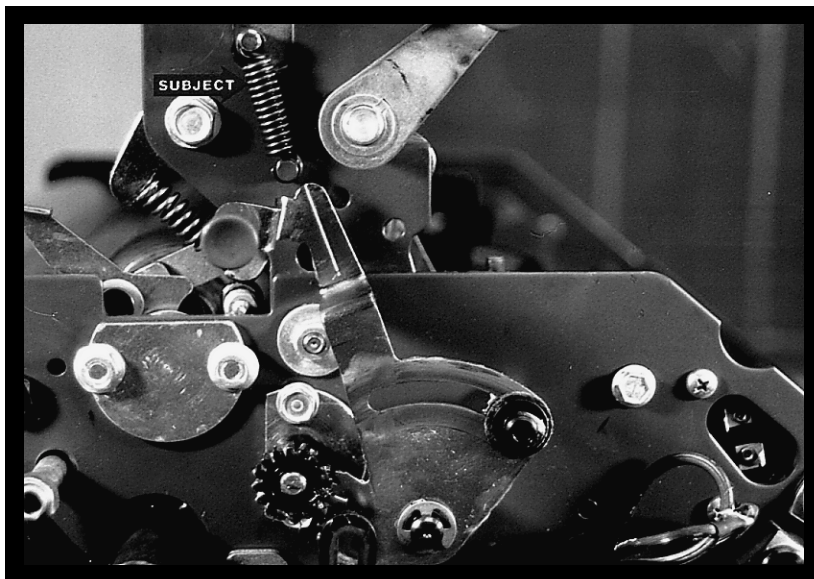
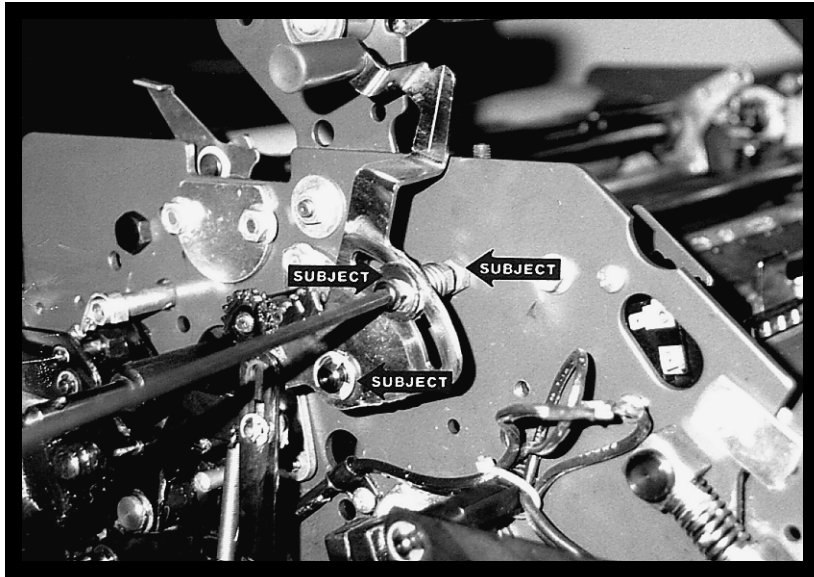

# DISASSEMBLY

**1**

Remove dampener and inker guards. Remove operating handles from OPS. Remove side covers from OPS & NOPS. Remove top 2 oscillating rollers from the ink train.

---

**2**

Remove dampener activating mechanism by removing "E" ring and cap head screw (subject arrows). Loosen the lock nut holding the cap head screw before attempting to remove it.

---

**3**

Remove vertical tension springs at OPS & NOPS (subject arrow).

**7**

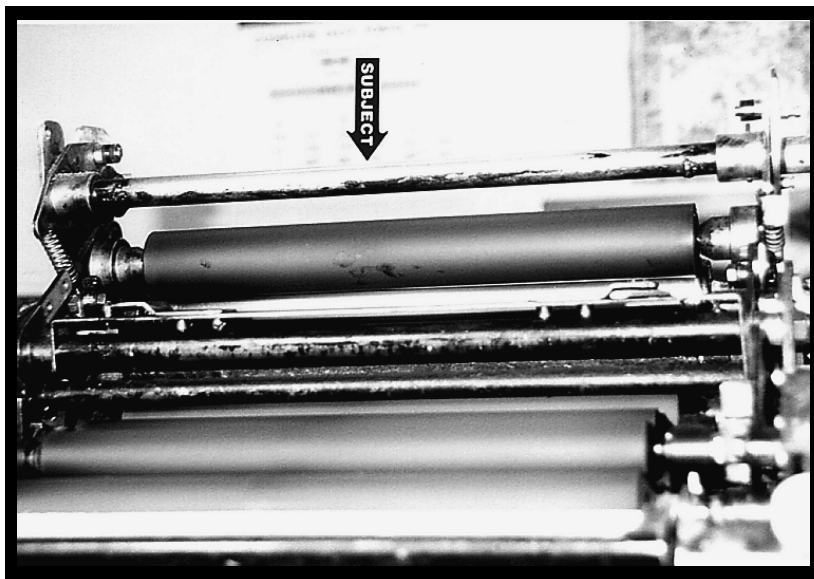
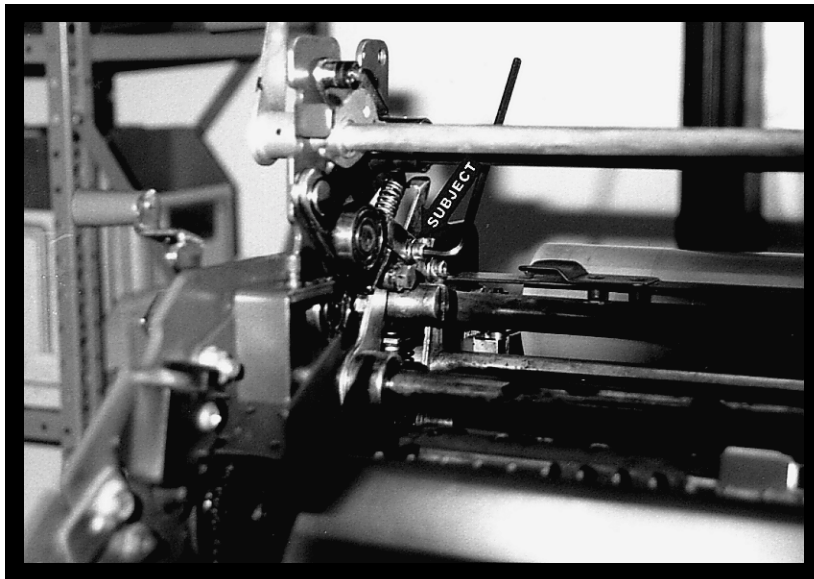
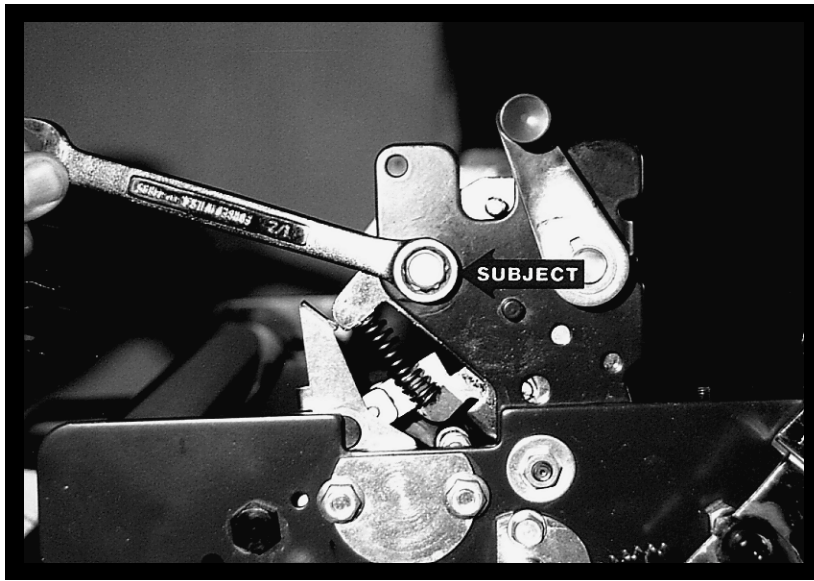



## DISASSEMBLY

**4**

Remove tie bar bolt (subject arrow) from dampener frame at OPS & NOPS.

---

**5**

Remove water lock out bracket (subject arrow) at OPS & NOPS. Brackets are short pieces of metal, each retained by 2 cap head bolts.

---

**6**

The metering roller assembly can now be removed by holding the tie bar (subject arrow) and pulling the mechanism out towards the ink rollers.

**9**

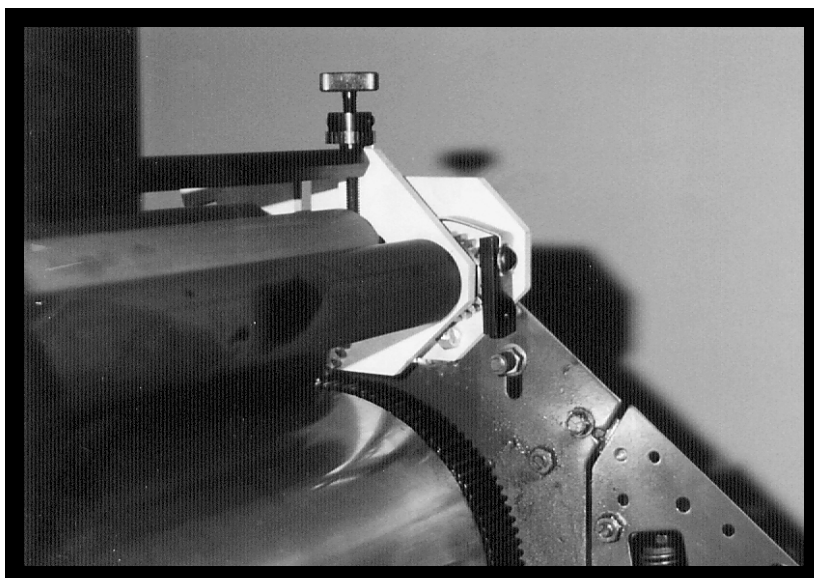
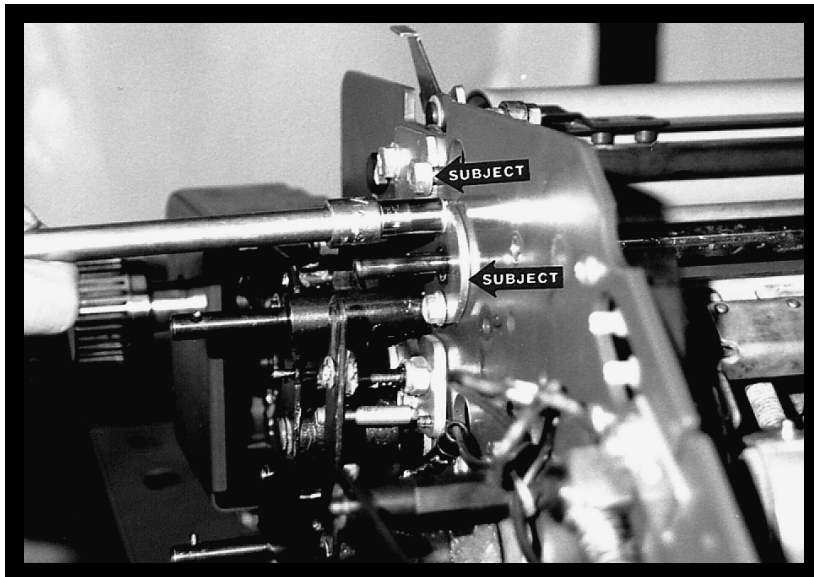
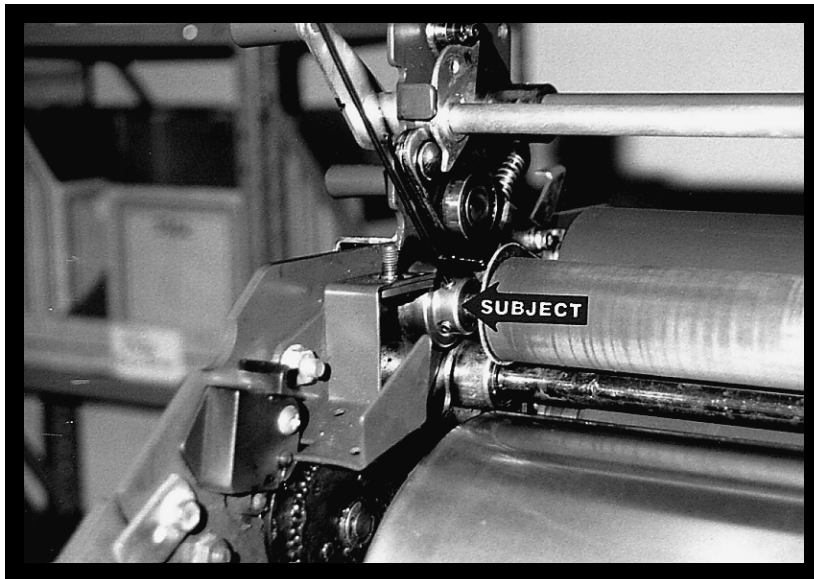

## DISASSEMBLY

7

Remove pan roller by loosening the 2 set screws on each collar at the OPS & NOPS and moving them toward the center of the press. There may be a small snap ring that holds the collar in place, if so, remove the snap ring before attempting to remove collar.

---

8

Remove bolt in the oscillator housing nearest the feed at OPS & NOPS. Also remove the 2 screws that hold the lift shaft housing at OPS (subject arrows).

---

9

Remove gear guard from the plate cylinder.

**NOTE: On some models the gear guard is attached to the gear and cam assembly. If it is, you must wait until step #16 to actually remove the assembly.**

**IMPORTANT: Replace nut immediately after removing guard.**

11

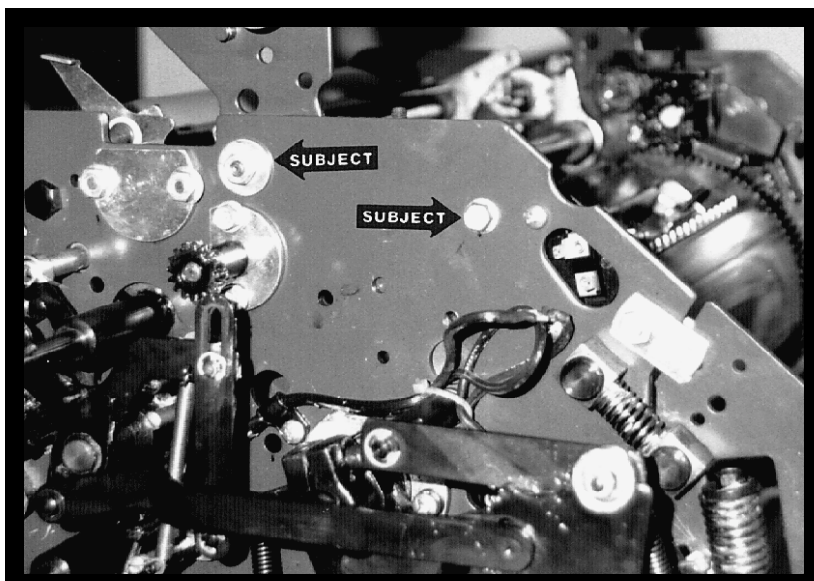
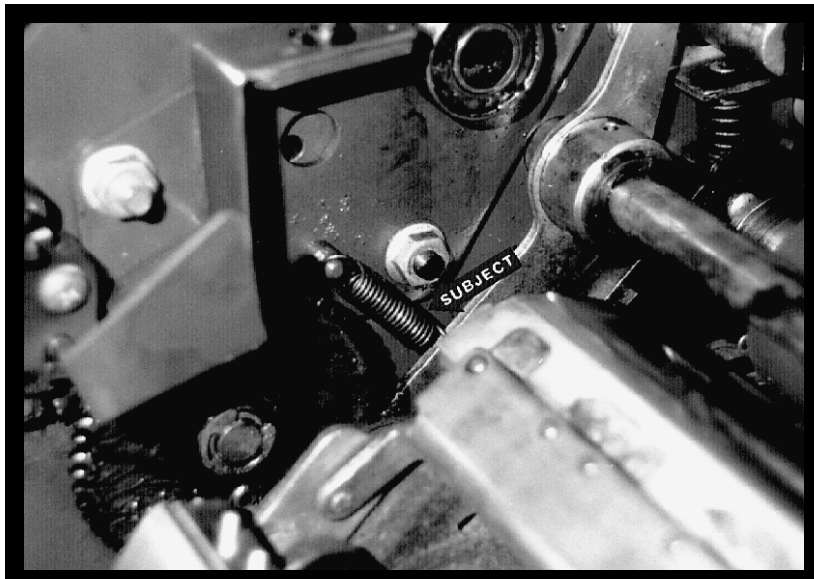
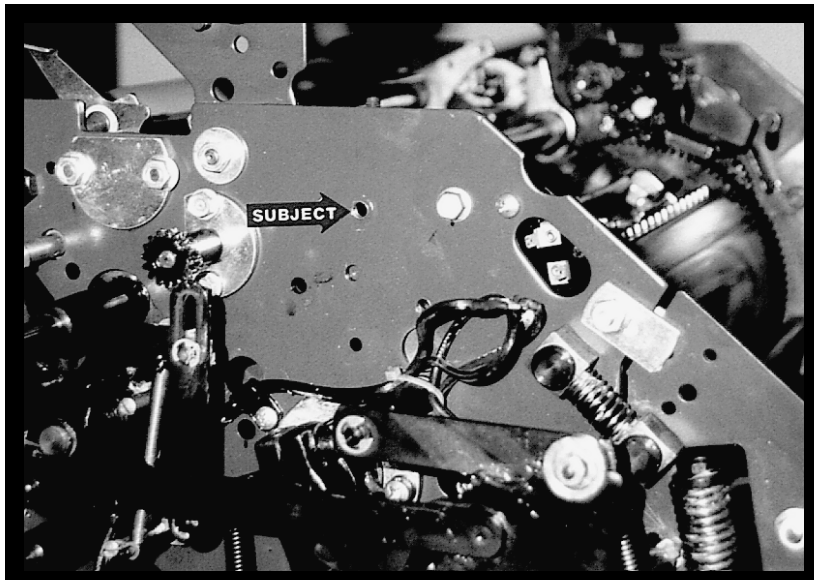

## DISASSEMBLY

**10**

Remove large stud from OPS that held the water activating mechanism. Photo shows stud already removed (subject arrow).

---

**11**

Unhook the spring attached to the water ductor arm (located near subject arrow) at both OPS & NOPS.

---

**12**

Remove bolts holding dampener frame to press at OPS & NOPS (subject arrow). Remove dampener frame from OPS. The shaft between the frames is removed with the OPS frame as one piece.

**13**

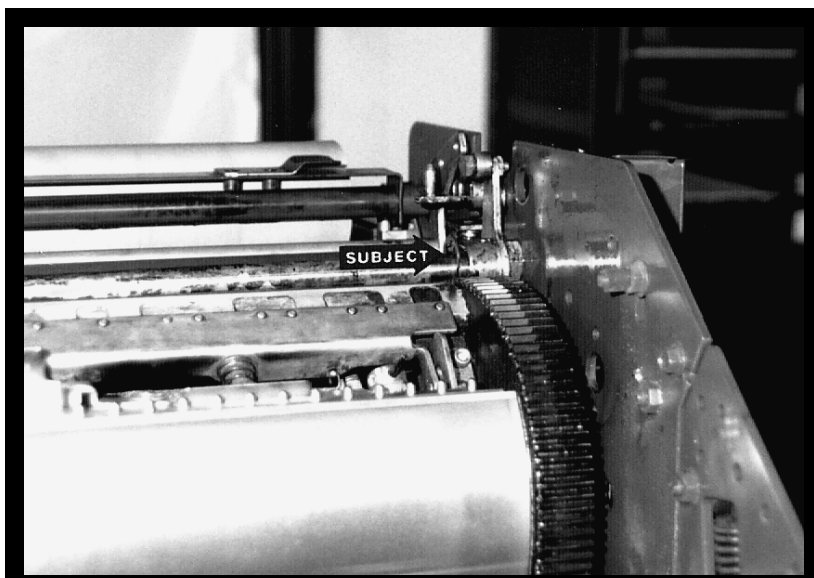
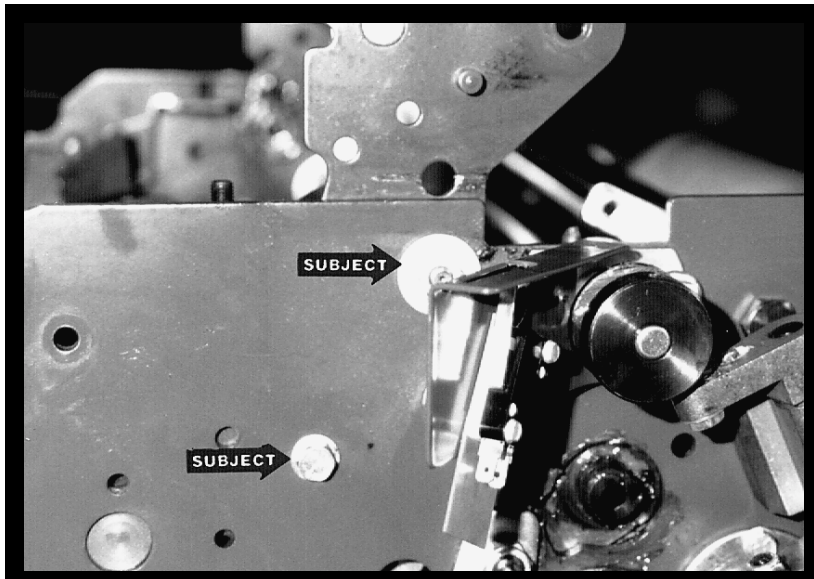
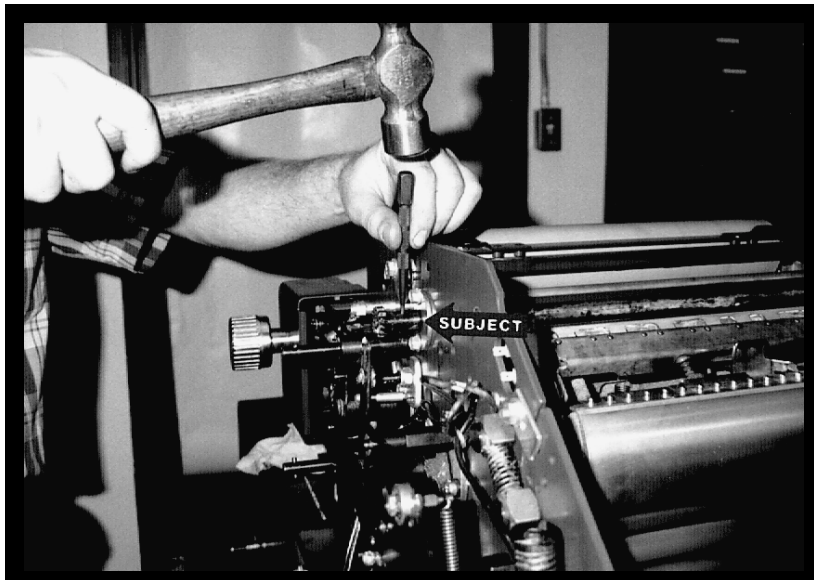

## DISASSEMBLY

**13**

Drive the **TAPER PIN** (make sure to hit the small end) out of the lift shaft gear & remove the gear and shaft housing from the OPS (subject arrow).

---

**14**

Remove the 2 nut and bolt combinations (subject arrow) at NOPS.

---

**15**

Remove the "E" rings on the lift shaft at the OPS & NOPS ("E" rings near subject arrow), push arms in toward the center and remove the shaft assembly.

**15**

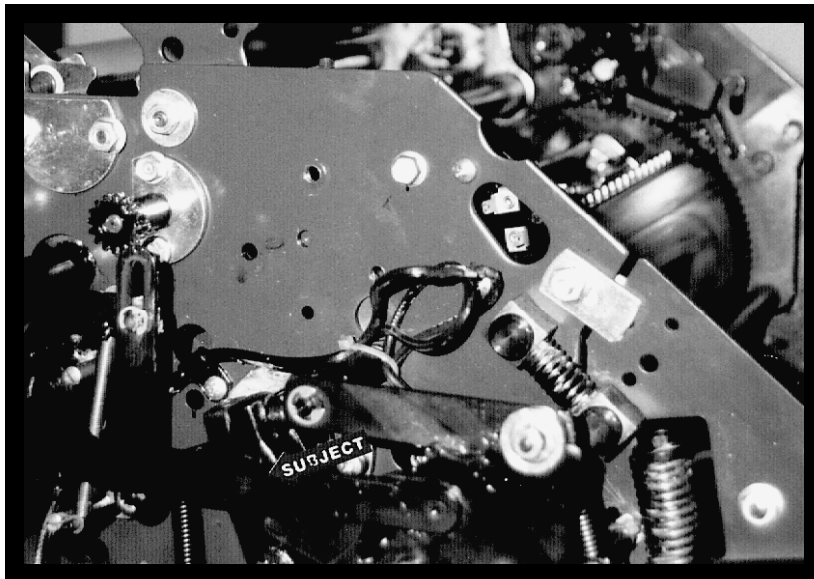
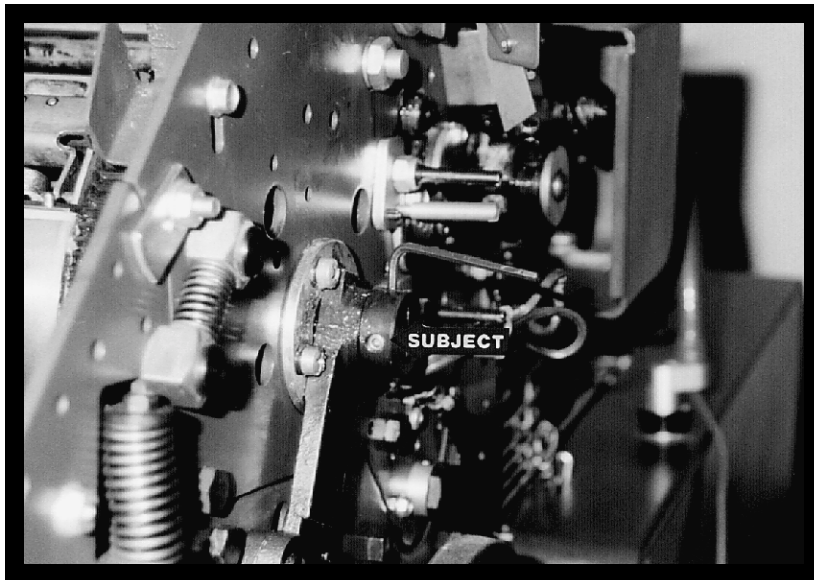



## DISASSEMBLY

**16**

Remove the NOPS dampener frame by loosening the collar on the plate cylinder shaft (subject arrow). Gently tap the plate cylinder toward operator side until there is enough clearance to pull out frame. Once the frame is removed, pull cylinder back toward NOPS and retighten set collar in its original position.

---

**17**

Remove night latch link (subject arrow), saving E-rings, washers, and spring for reinstallation.

---

**18**

Clean insides of press frames thoroughly with solvent and a rag.  
**YOU ARE NOW READY TO INSTALL CRESTLINE®.**

**17**

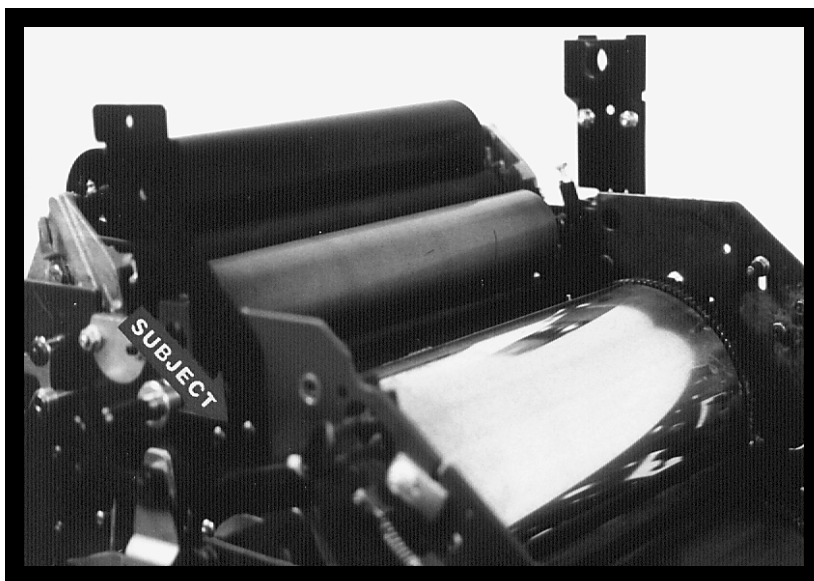
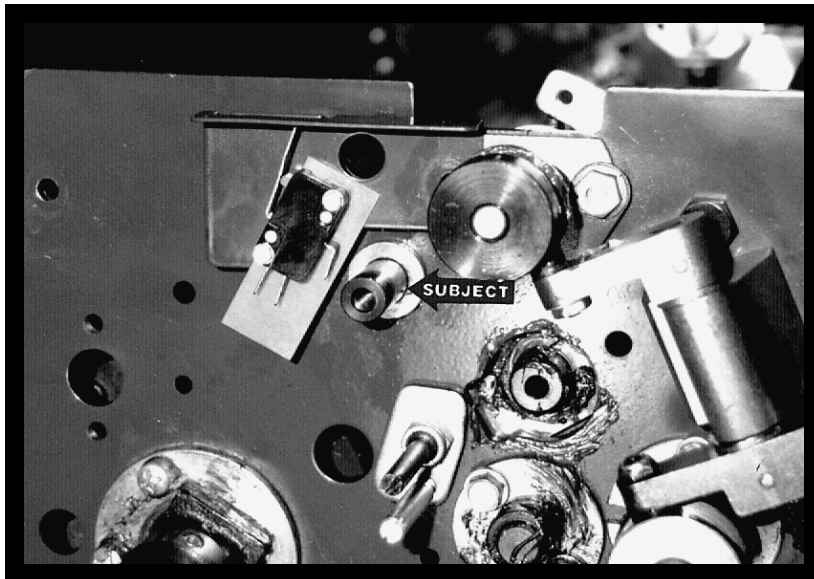
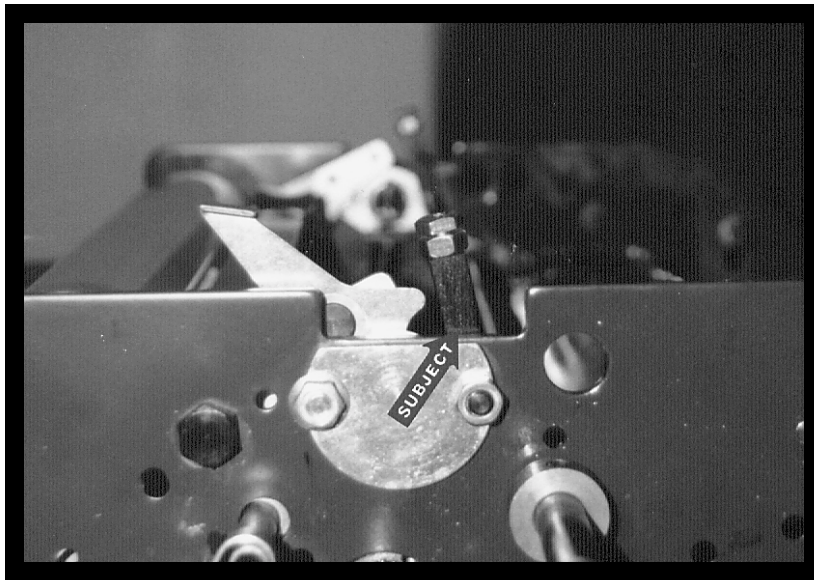

# INSTALLATION

1

Install water form adjusting mechanism at OPS & NOPS by inserting the spring stud through mechanism and then through the vacant hole in the ink oscillator housing (the original bolt was removed in disassembly step 8). Angle the mechanism toward the delivery end of the press and finger tighten nut #05-244.

---

2

Install lift shaft #15-03 by inserting the longer portion that extends past the cams into the 5/8" hole in the OPS then dropping the shaft down into the press and through the same hole at NOPS. **DO NOT MOVE CAMS TO INSTALL THE SHAFT.** Slide on the bronze bearings #06-346038 (subject arrow) at each end of the shaft with the flange to the outside, and press into the frame. Light tapping around bearing flange is usually sufficient to seat it. If the bearings appear to be fitting too tightly in the holes, do not force them. Remove shaft and bearings, take a rat tail file and clean off paint from the inside of the holes, and repeat the shaft installation process. Once the bearings are seated, thread provided hex-head bolt #05-114075 and washer #05-314662 into NOPS (set collar used in place of bolt and washer on 8800 series) and slip set collar #13-5043 on OPS lift shaft. Do not tighten at this time.

---

3

Install guard mounting plates #18-0334 & #18-0335 at OPS & NOPS using the provided button head bolts #05-134050 and flange nuts #05-244 (subject arrow). The 2 piece bracket goes on the NOPS.

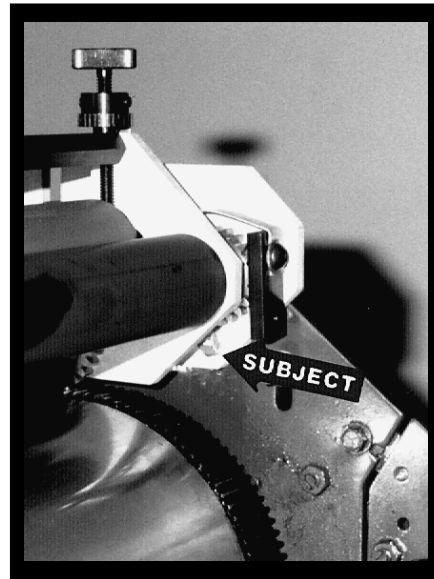
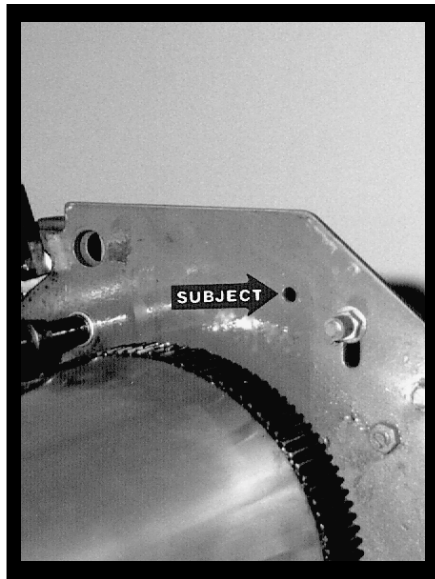
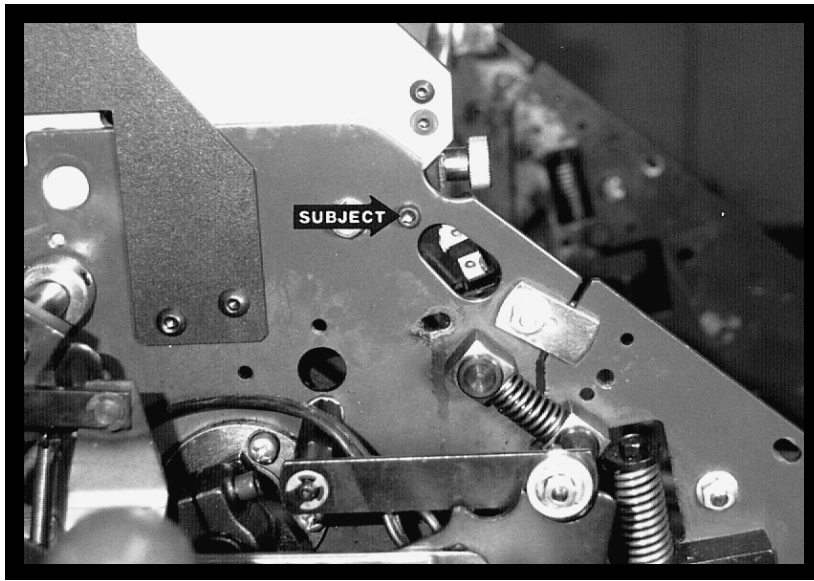

## INSTALLATION

**4**

Sit the dampener down in between the side frames making sure gears mesh. You may have to reposition OPS safety switch slightly by loosening cap head bolts (subject arrow).

---

**5**

Insert mounting bolts #05-114075 and spools #12-112031 (subject arrow, right hand picture) through the dampener & into the holes in the press frame. Left hand picture shown without dampener to illustrate which hole in frame to use.

---

**6**

Secure mounting bolts with provided flange nuts #05-244. After tightening nuts, make sure dampener pivots up and down freely.

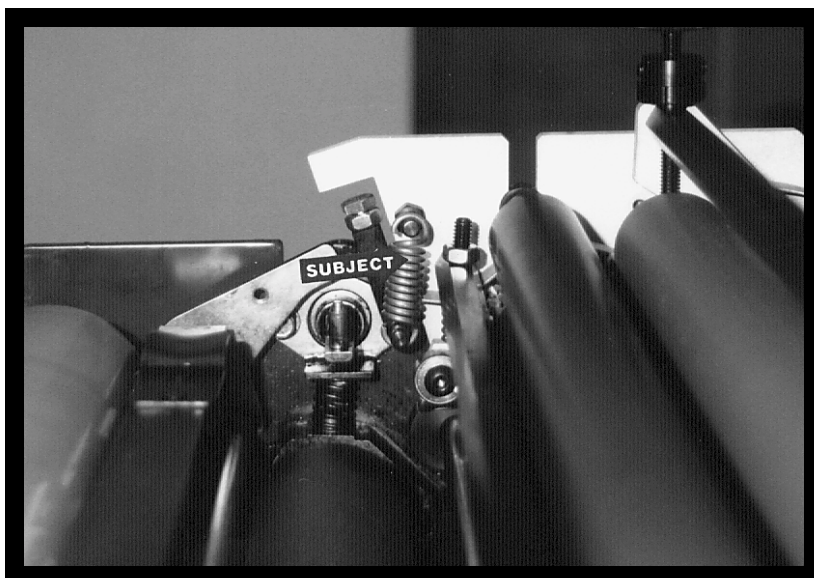
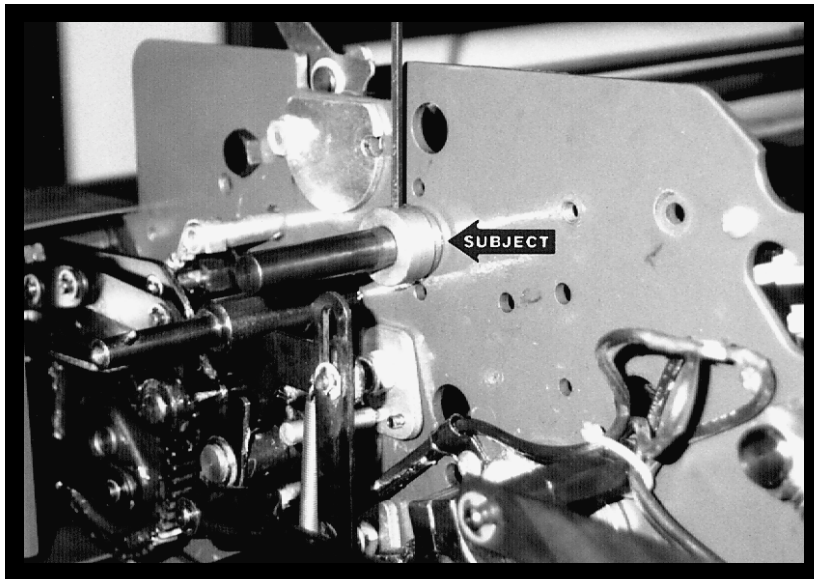

# INSTALLATION

**7**

Position lift shaft side to side so the cams are spaced equally between the bearings on the hanger brackets and lock the position of the lift shaft with the set collars (subject arrow). The flat portion of the cam should be facing up.

---

**8**

Position water form adjusting mechanism at OPS & NOPS (subject arrow) so they are parallel with the dampener frame as shown and fully tighten nut on outside of press frame.

---

**9**

Install springs #09-0101 between dampener spring stud and the spring stud in the water form adjusting mechanism (subject arrow).

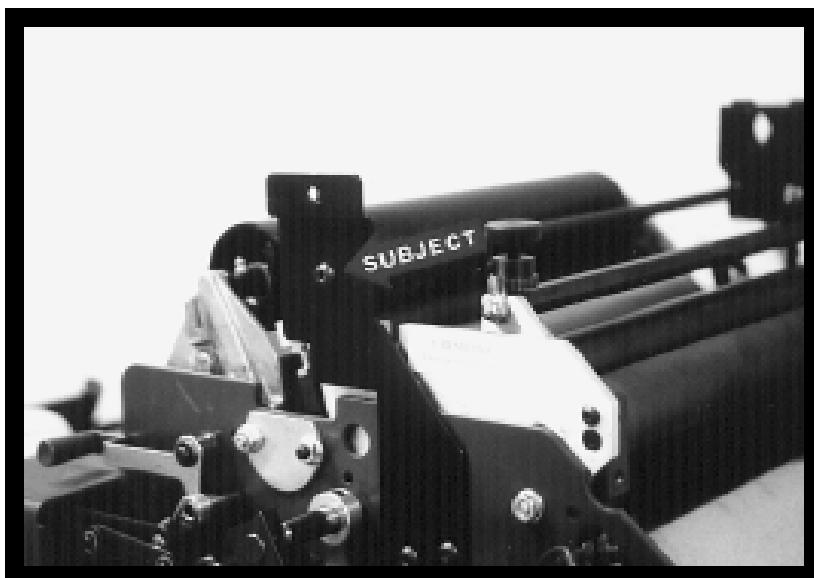
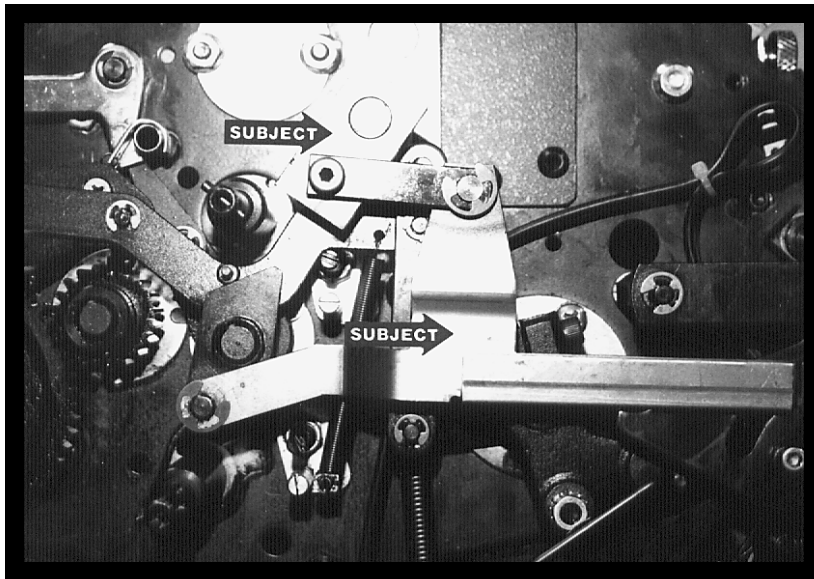



**10**

Replace the night latch link on the press with the new linkage provided by Accel #17-0501 (lower subject arrow). Picture is shown with single lever on the water off or night latch position. If the linkage is installed pre-assembled (as shown in picture), you will slip the control block #17-0303 (upper subject arrow) over the lift shaft as you connect the linkage in the same manner as the original one.

Install the new spring #09-0105 provided for the sequence cam truck arm.

---

**11**

Place the single lever in the "water on" position (2nd detent). Rotate the lift shaft clockwise until the cams contact the ball bearing on the dampener hanger brackets. Holding the shaft in this position, tighten the set screws in the control block (shown in previous picture, upper subject arrow). Return the single-lever shaft to the off position. The cams should rotate clockwise and the ball bearings on the dampener hanger brackets should rest over the "corner" of the cam (subject arrow, right hand picture).

---

**12**

Attach the tie bar to the mounting plates installed in Step 3, using button head bolts #05-134038 (subject arrow).

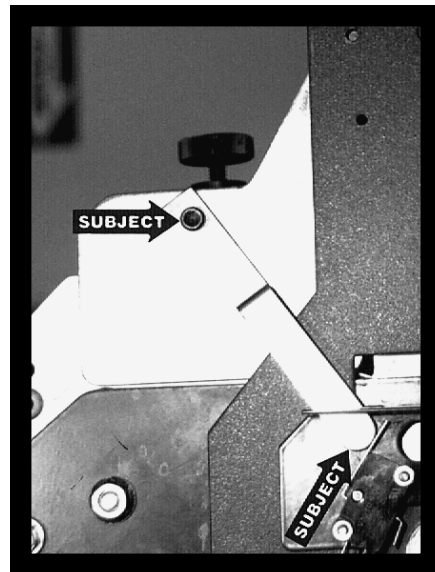
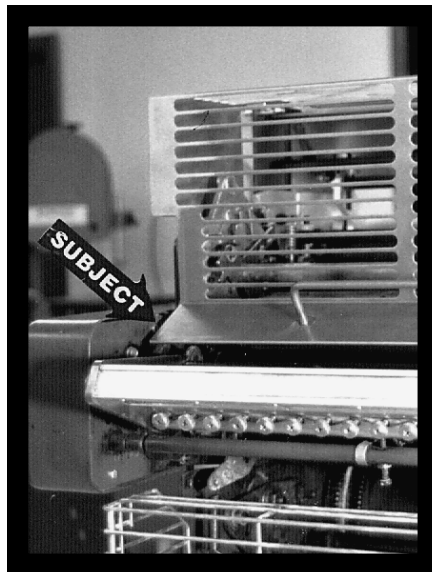
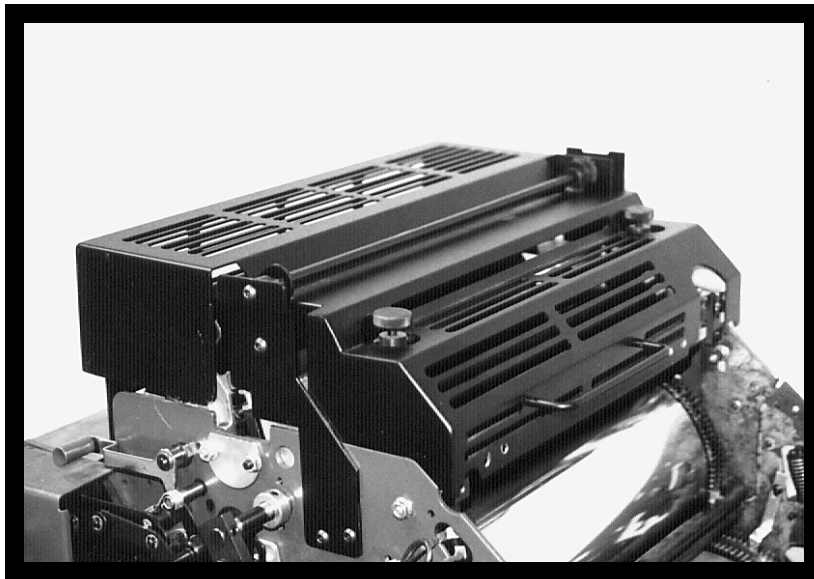
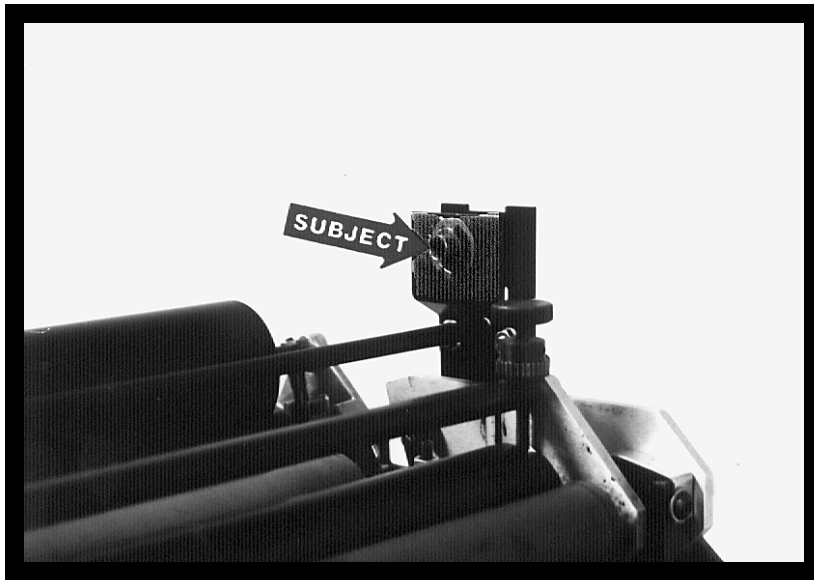

**13**

Install the inker guard cam (9870 models) or pivot sleeve #18-0339 (8800, 9810-9850 models) (subject arrow) in the NOPS mounting plate using the E-ring #99-197 to secure it.

**14**

Set the inker guard and dampener guard on the press and insert the cam/pivot rod through the inker cam, the tabs on the guards, and into the hole on the OPS mounting plate. Install original E-ring on the shaft by the NOPS dampener guard tab.

**15**

**FOR 8800 SERIES, 9810 - 9850 INSTALLATIONS,** remove the magnet from original inker guard and attach to the new one (subject arrow). Attach the plunger (subject arrow, right picture) to the NOPS side of the dampener guard.

**NOTE: It may be necessary at this point to adjust the guard mounting plates so that the guards are squarely aligned and the microswitch tripping mechanisms operate properly.**

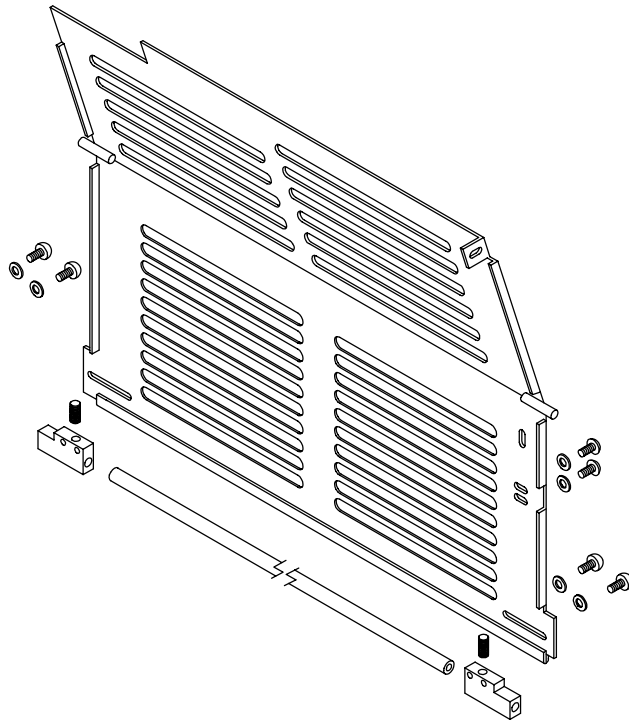
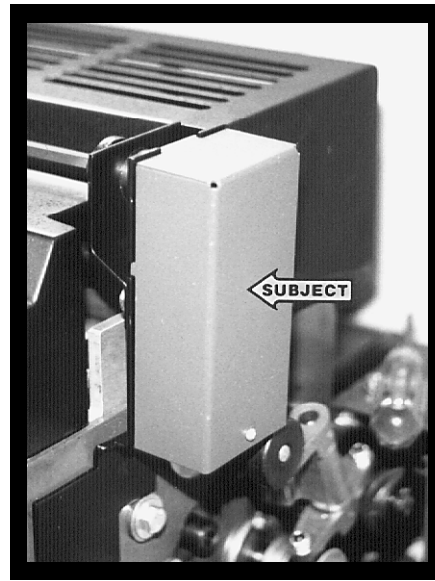
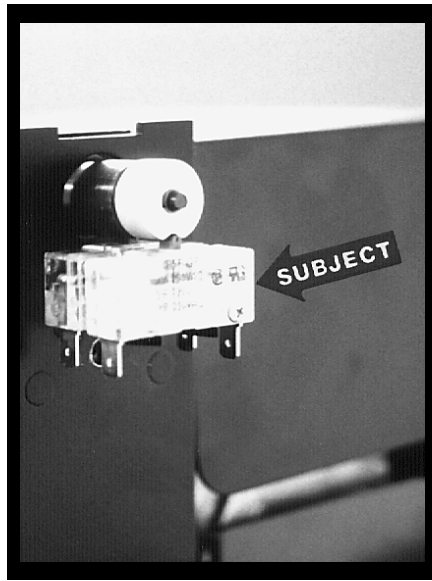

AB98GA1, 6/96

**16**

## **FOR 9870, 9900 INSTALLATIONS**

Attach the original microswitches (subject arrow, left picture) to the NOPS mounting plate. Attach the originally supplied cover (subject arrow, right picture) to the mounting plate.

---

**17**

## **FOR 8800, 9800 INSTALLATIONS**

Loosely attach the guard mounting blocks to the guard using the button head screws, using the upper slot. Many A. B. Dick machines are now equipped with a rod which has a trip cam on the NOPS. If so, slip this rod through the NOPS frame and through the blocks you just installed on the cylinder guard. Slide the blocks on the guard out and butt up against the press frames. Tighten the button head bolts at this time to remove any end play. Each block has a set screw. Position the rod for proper microswitch activation and tighten the set screws to secure this position on the rod. If your press is not equipped with this style of guard and did not have the rod, use the rod provided by Accel. Follow the steps above. However, you must remove the magnet from the original guard and place it on the new guard.

---

**18**

## **FOR 9900 INSTALLATION**

Install the supplied cylinder guard exactly as the original and set microswitch trip cam.

**YOU ARE NOW READY TO MAKE FINAL ADJUSTMENTS.**

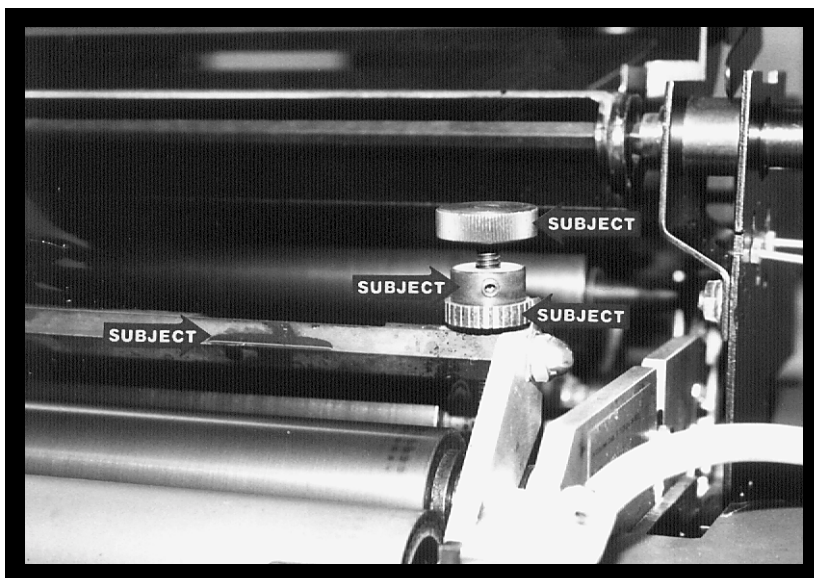
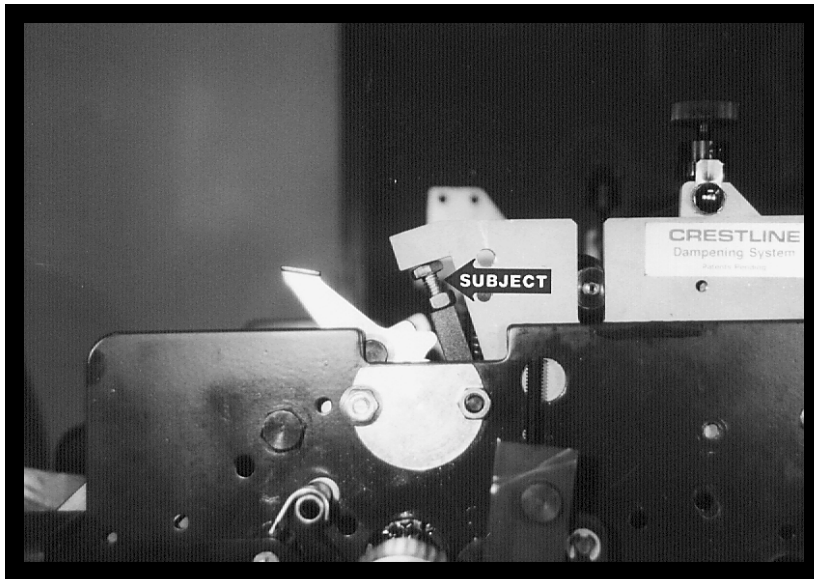

# FINAL ADJUSTMENTS

1

## FORM ROLLER LIFT AND GEAR MESH

Place single lever in night latch position and mount a plate to the press. Adjust set screws on the dampener frame tie bar (#1) until you have an equal amount of clearance over a printing plate. Turning the screws down increases the gap between the form roller and plate cylinder and vice-versa. There should also be a gap between the metering roller and the form roller (subject arrow). After proper lift is obtained, tighten lock nuts.

2

## FORM ROLLER TO PLATE CYLINDER PRESSURE

Dab some ink on the oscillator and turn on the press. Move the single lever to the "Neutral" ("On" for multi lever machines) position to distribute the ink on the dampener. Place the dampener in the "Night Latch" position and turn off the press.

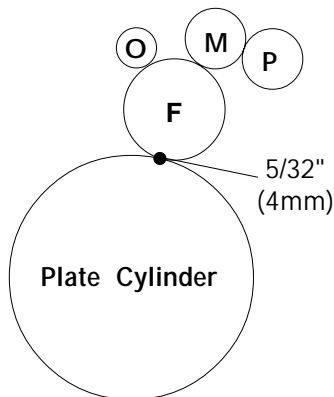

Lower the dampener to the plate and back off again. This will leave a stripe. The proper setting is an even 5/32" across the plate. Adjust the stripe by turning the bolts (subject arrow) in the water form adjusting mechanism. Turning the bolts down drops the dampener and makes a wider stripe. Adjust it to 5/32" stripe to the plate and tighten lock nuts against adjusting mechanism.

3

## MAXIMUM METERING TO PAN ROLLER PRESSURE

Place the single lever dampener in the "Night Latch" position. Spin the ratchet gears (lower right subject arrow) down until they stop against the cross bar (far left subject arrow). They are not yet locked to knobs). Turn the press on and let the press idle for 20 seconds. Check the stripe between the pan the metering rollers. It should be 3/16". Adjust by turning the knurled knobs (top right subject arrow). Turning the knobs down makes a wider stripe. Once the stripe is correct, lock the ratchet gears to the knobs by tightening the set screws (middle left subject arrow) (2 each). This position sets minimum water.

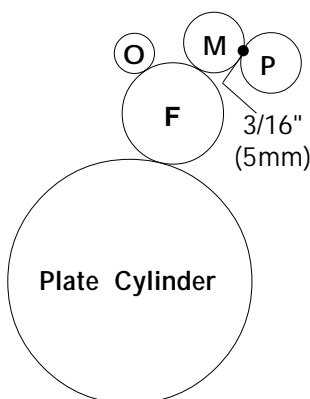

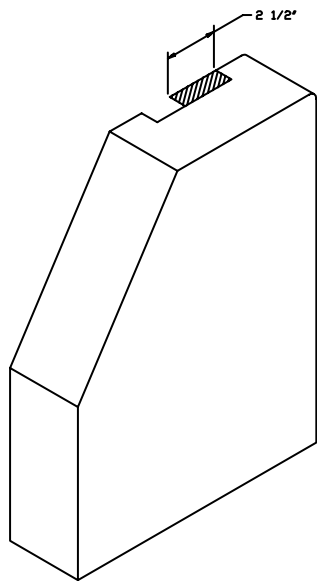



# FINAL ADJUSTMENTS

**4**

Installation of Crestline results in the following changes in the single lever positions:

1. Night latch becomes the "Off" position.
2. Neutral becomes the "Water On" position.
3. Ink & Water position drops the ink forms to the plate.

**5**

## **WATER LEVEL IN PAN**

Install the water pan and bottle. Set the water bottle in the pan and adjust the water level by adjusting the bottle. Raising the bracket will raise the pan level and vice-versa. Water level should be about half way up the pan.

**6**

## **REINSTALL COVERS**

Install all of the covers on the press.

**NOTE:** On some older 9800 Series models, it may be necessary to modify the NOPS side cover to clear the guard mounting bracket. Using a hack saw, remove a 2 1/2" portion as shown in the diagram.

## BASIC OPERATION

- START OF DAY**
- A. Make sure the oscillator and metering rollers are in place.
  - B. Spin knurled knobs until the shoulder on the ratchet stops against the bar.
  - C. Mount plate to cylinder. Wipe down all plates before running. Pre-ink the Crestline dampener before running the plates with an extremely light coverage of ink. Dab the ink on the oscillator only.
  - D. Place water bottle in bracket.

**NOTE:** Accel recommends using the proper fountain solution for the plate material being run on the press. A good acid/gum etch should be used with metal plates.

- 
- RUNNING DURING THE DAY**
- A. In general, the Crestline Dampener should not have to be adjusted from job to job. The form roller setting should never be changed unless it has deviated from the factory specification of 5/32" to the plate.
  - B. Adjustments to the amount of water fed to the plate are made by the knurled knobs that apply pressure to the metering roller. The dampener has been set up for minimum water. To increase the water to the plate, turn the knurled knobs counterclockwise 1 or 2 clicks at a time. This opens the gap between the metering and pan rollers and allows more water to the plate.
  - C. In general, more water will only be required when going from a metal plate to an electrostatic or Silvermaster type plate.

# CLEANING & MAINTENANCE

## WASH UPS DURING THE DAY

1. Remove bottle and drain the excess water from the pan.
2. Mount cleanup mat to the press or if applicable, a wash-up attachment along with a metal plate to act as a bridge between dampener and inker.
3. Turn on the press and squirt a small amount of press wash on the ink and dampener rollers. (Squirt ink rollers only if using a wash-up attachment.)
4. Drop both the dampener and ink forms to the plate. If using an attachment, generally the dampener will pick up enough roller wash off the plate to clean itself, so apply wash directly to the dampener only when necessary.
5. Remove water pan and clean any solution left in it.
6. Be sure to wipe excess clean up solution from the ends of the dampener metering and pan rollers.

---

## END OF THE DAY

1. Wash up dampener. Pay close attention to cleaning the ends of the pan and metering rollers that extend past the form rollers.
2. Spin the knurled knobs up until the metering roller can be removed.
3. Remove metering roller and wipe down thoroughly to remove any excess wash that may be on the roller.

## CLEANING & MAINTENANCE

### **DEGLAZING THE DAMPENER**

Periodic deglazing of water-soluble contaminants will be necessary with the Crestline. Typically, once every 2-3 weeks will be sufficient, unless you are running electrostatic plates on a daily basis whereas deglazing should be performed weekly. A 50/50 solution of household ammonia and hot water can be used for deglazing purposes. If you prefer a commercially available deglazer, avoid those containing pumice or gritty substances. Always follow deglazing with straight water and then roller wash. Accel offers a product called **COMPOUND X** that we recommend for deglazing our system. Contact your dealer or Accel for more information.

---

### **OILING AND GREASING THE DAMPENER**

- A. Place a small amount of grease on the gears once a month.
- B. Inject grease into the oscillator grease fitting once a month.

# CLEANING AND MAINTENANCE

## CRESTLINE® CLEANING & MAINTENANCE CHART

	Daily	Weekly	Bi-Weekly	Monthly
Wash Rollers	✓			
Deglaze Rollers				
Metal Plate Users			✓	
Silvermaster Plate Users			✓	
Electrostatic Plate Users		✓		
Grease Gears				✓
Inspect Ball Bearings				✓
Check Roller Pressures				✓
Check Roller Surfaces				✓

AB DICK 8800 OPS SIDE FRAME ASSEMBLY

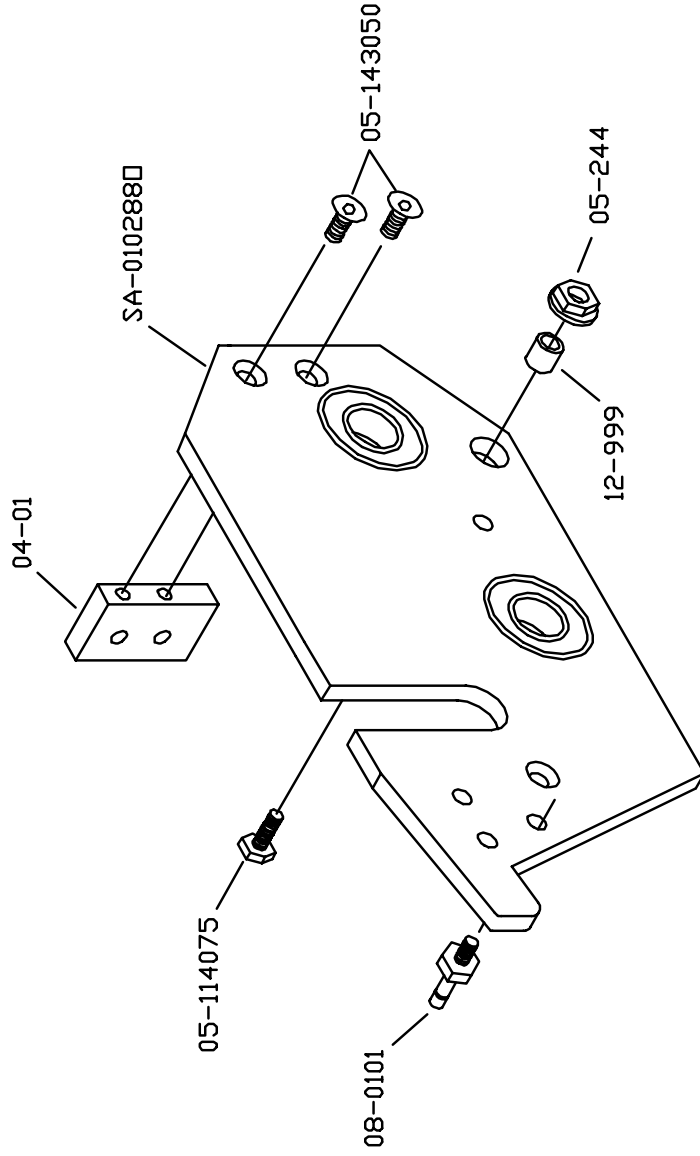

AB DICK 8800 NDPS SIDE FRAME ASSEMBLY

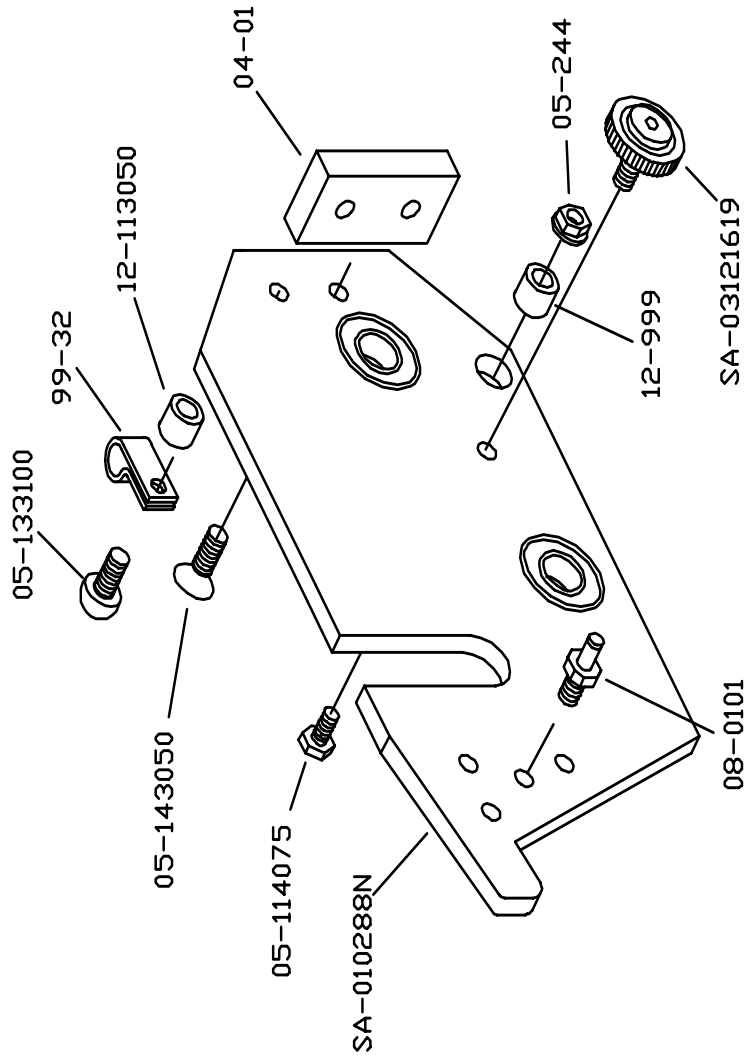

8800C03, 1-26-97

AB DICK 8800 PAN ROLLER/HANGER ASSEMBLY

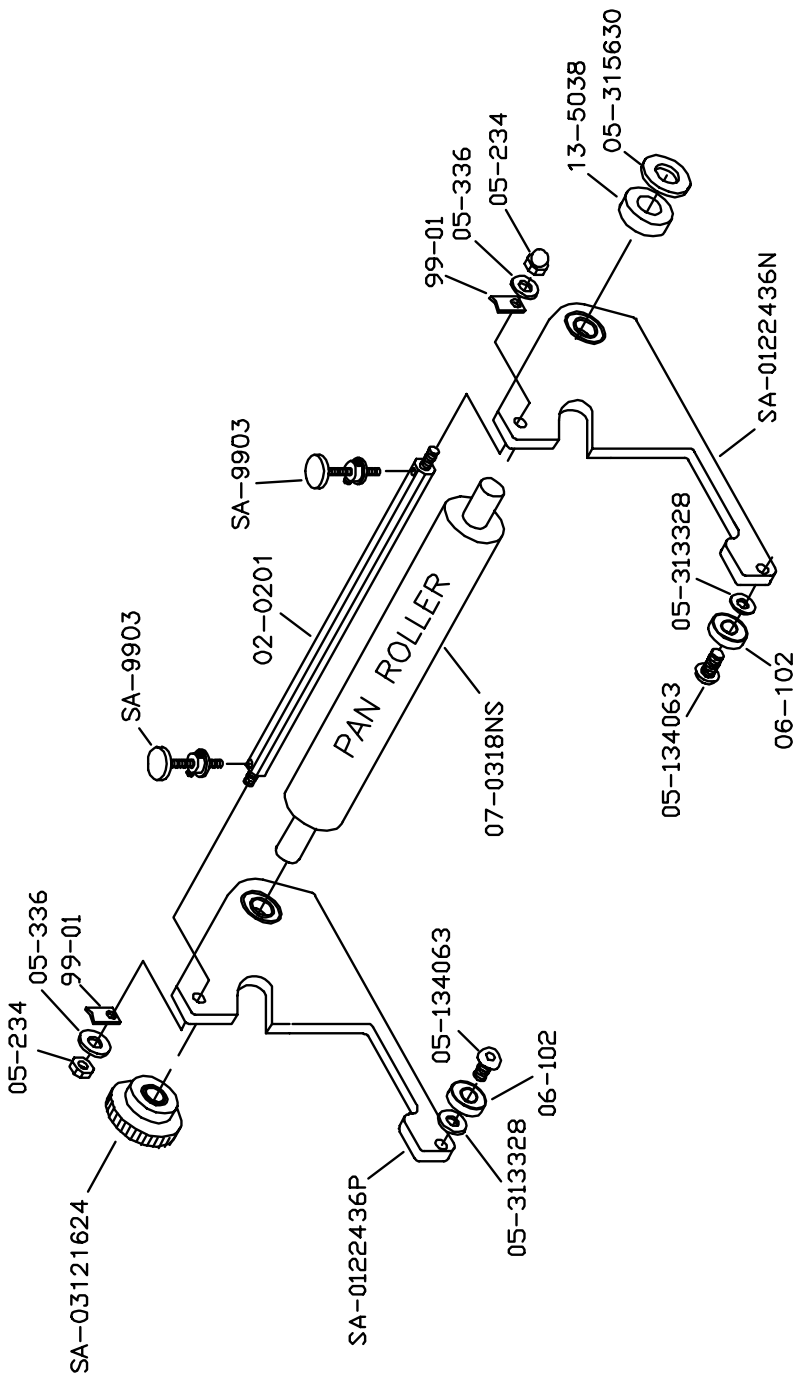



AB DICK 8800 FORM ROLLER ASSEMBLY

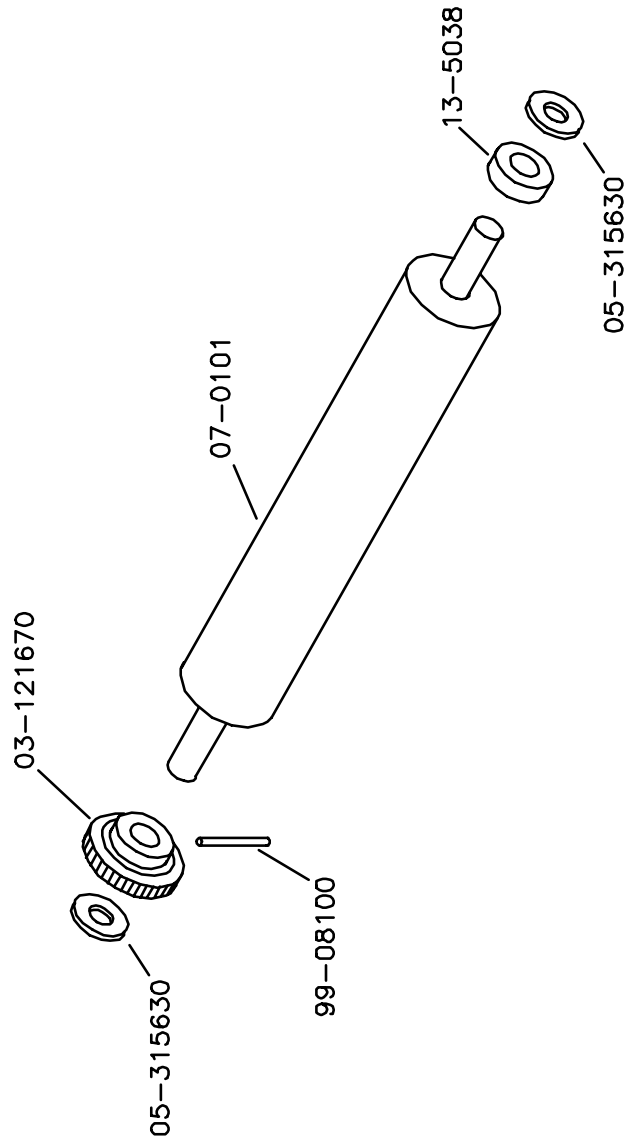

8800C06, 1-27-97

AB DICK 8800 DAMPENER ASSEMBLY

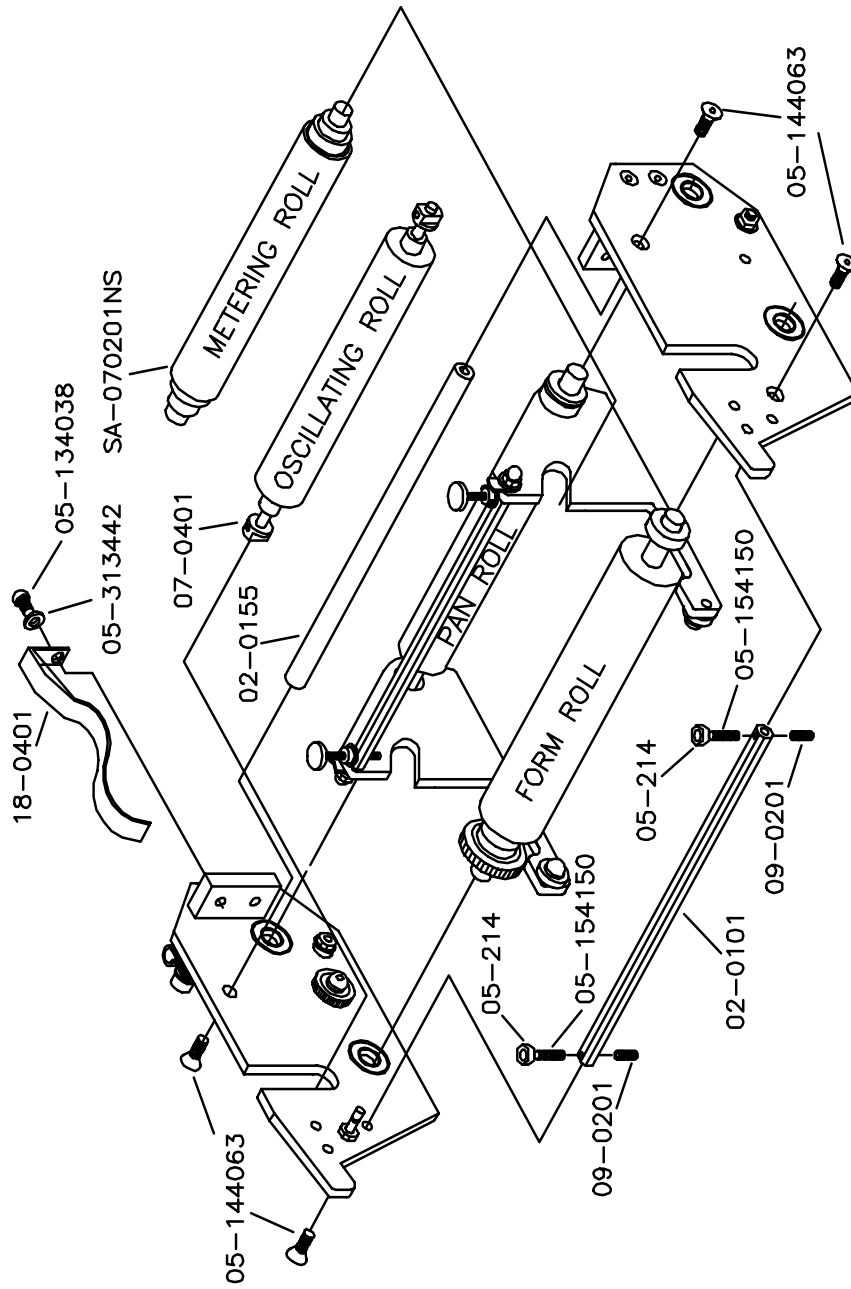

AB DICK 8800 WATER PAN ASSEMBLY

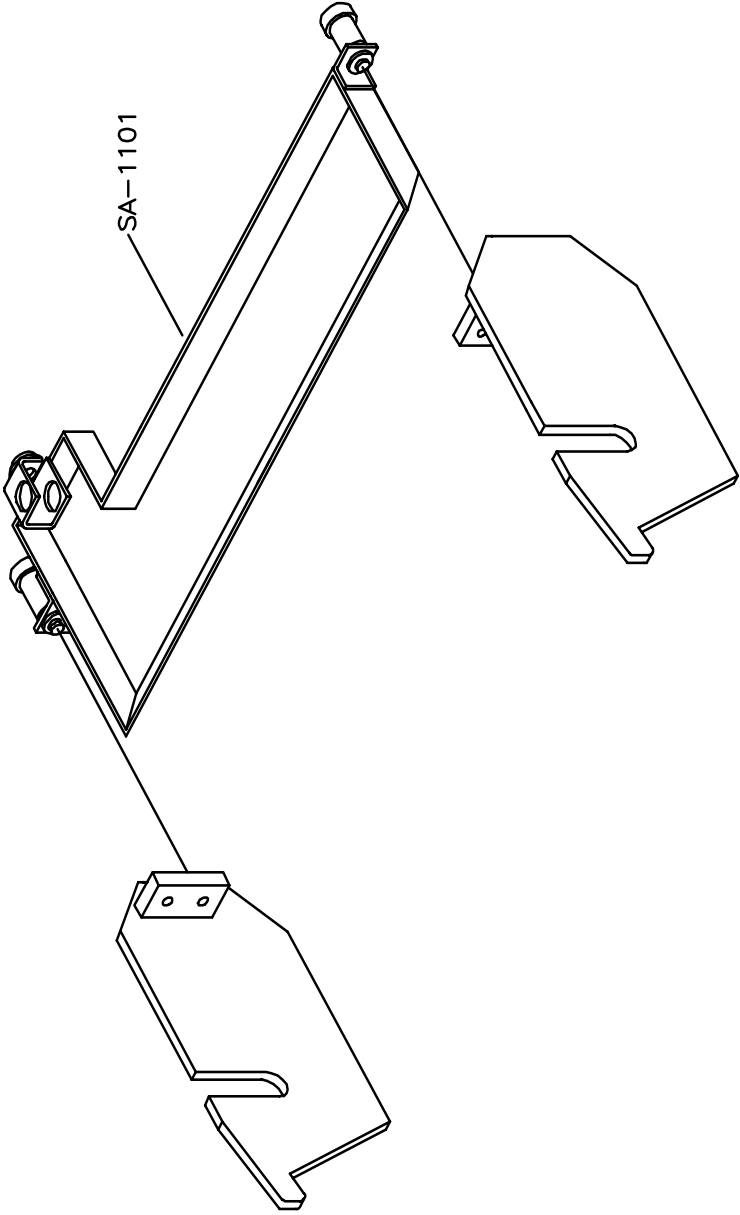

8800C08, 1-27-97

PLATE CYLINDER GUARD MOUNTING HARDWARE  
AB DICK 8800

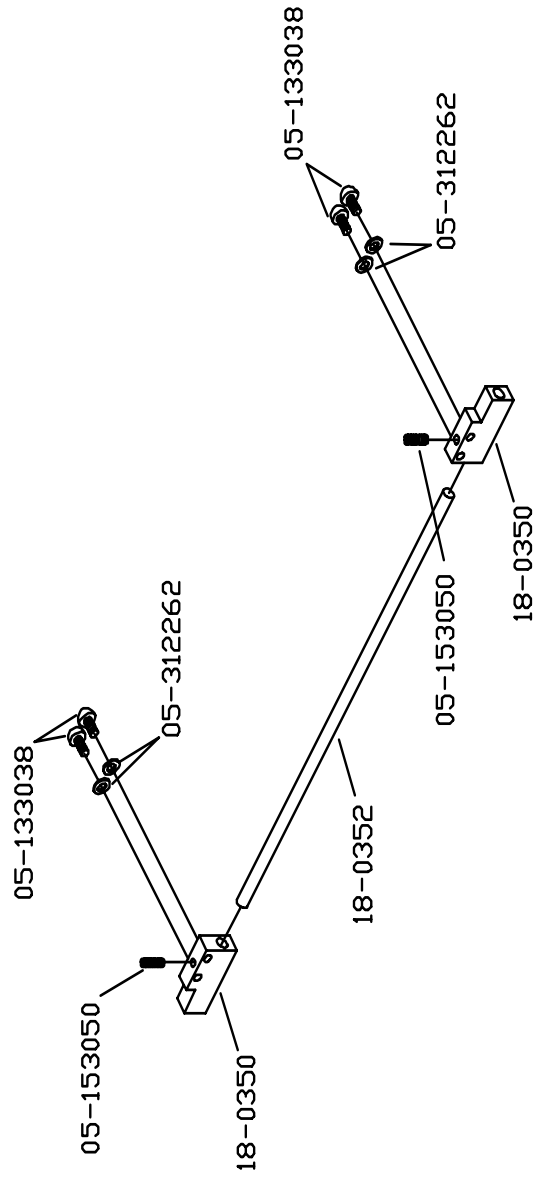

DAMPENER AND INKER GUARD MOUNTING HARDWARE  
 AB DICK 8800

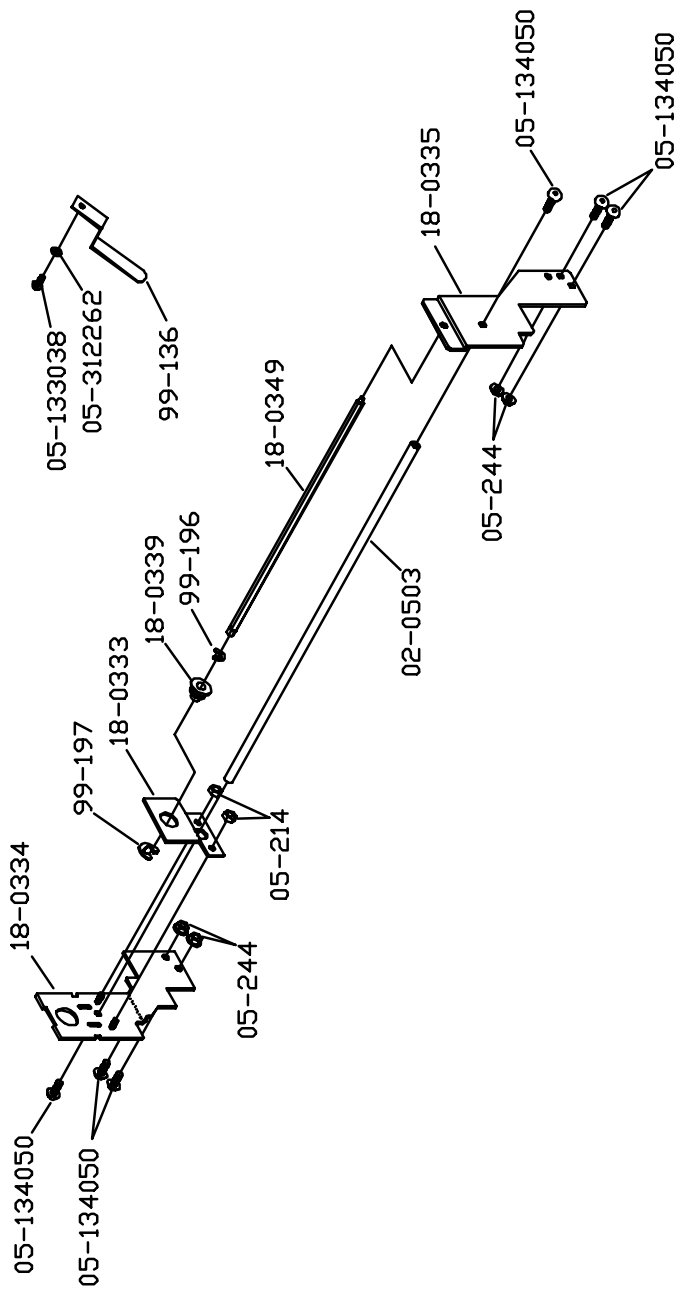

8800C10, 3-6-97

AB DICK 8800 ACTIVATION ASSEMBLY

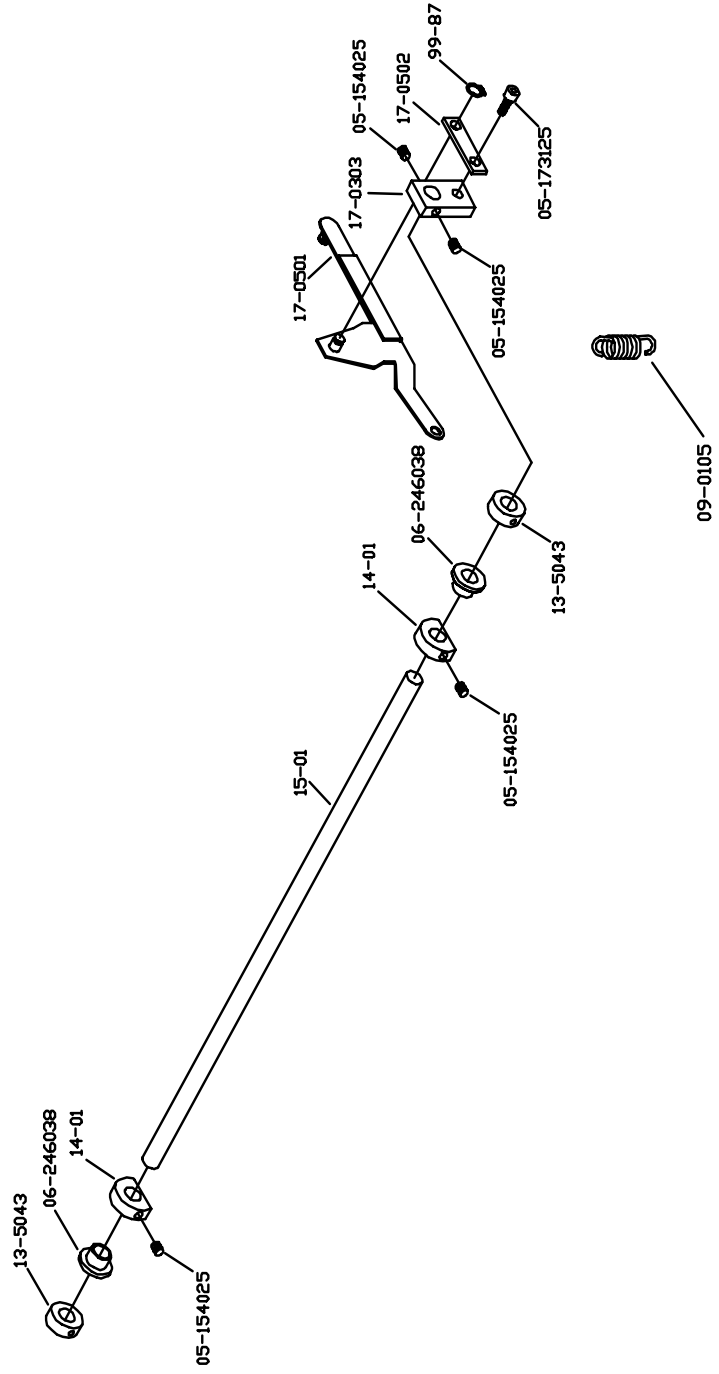

8800C11, 1-27-97

AB DICK 8800 STRIPE ADJUSTMENT ASSEMBLY

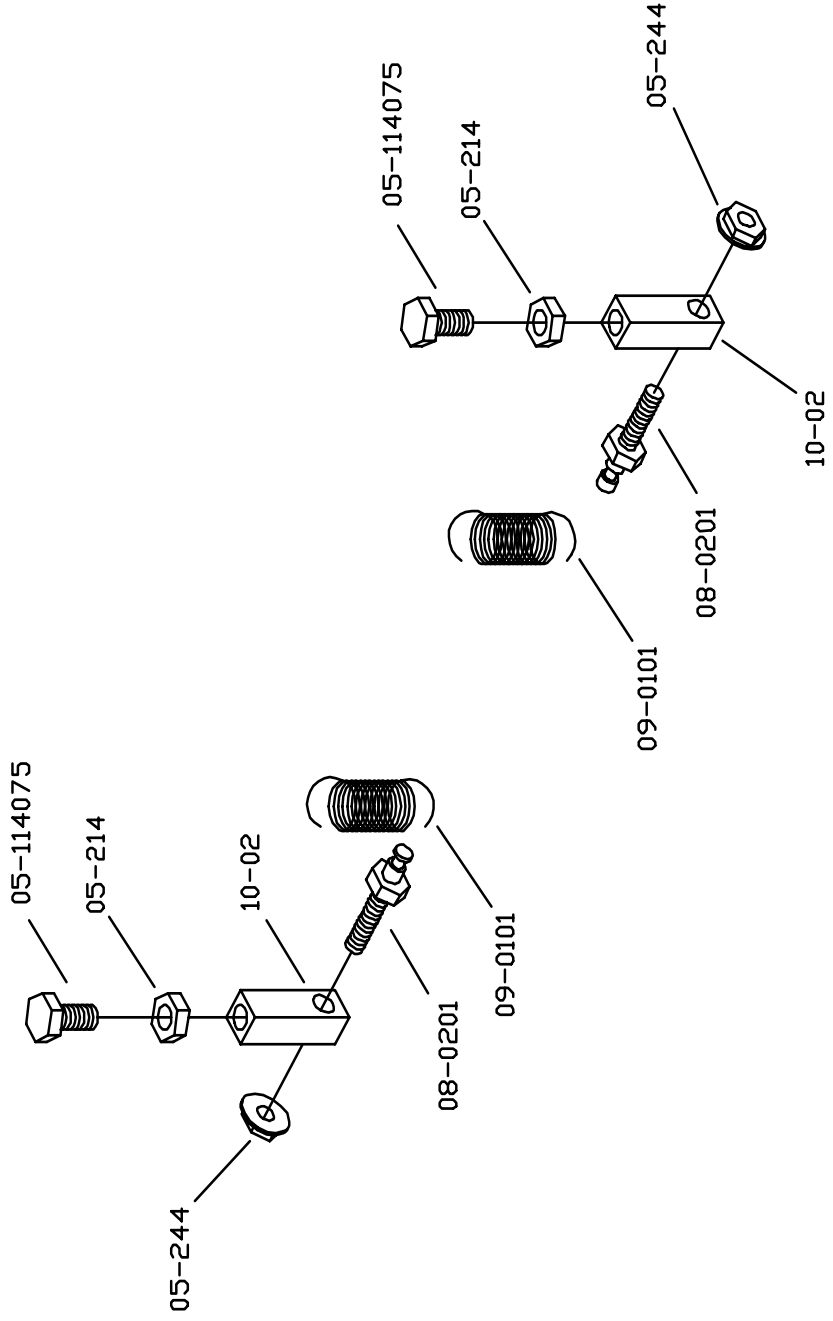

8800C12, 1-27-97

WATER BOTTLE ASSEMBLY  
AB DICK 8800

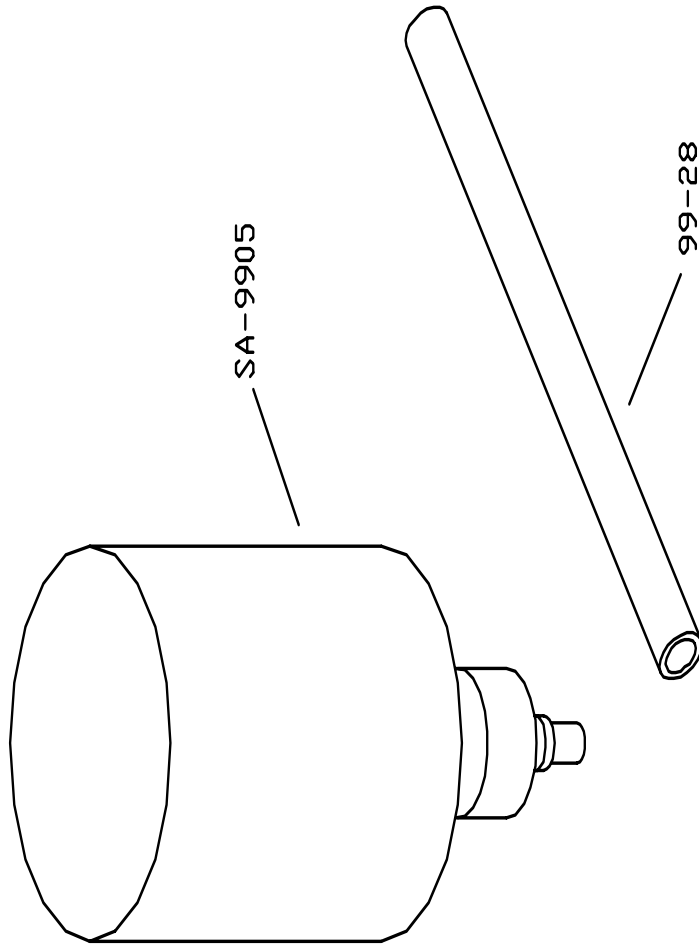

8800C13, 3-6-97



SUPER T-HEAD GUARD ASSEMBLY  
AB DICK 8800

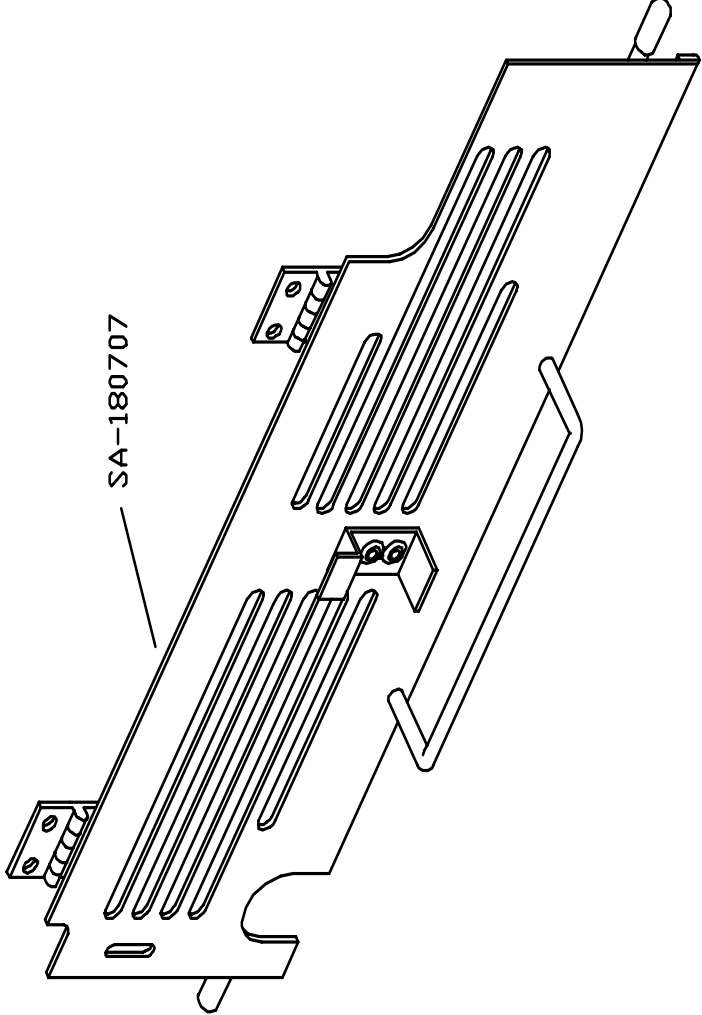

8800C14, 3-6-97

T-HEAD GUARD ASSEMBLY  
AB DICK 8800

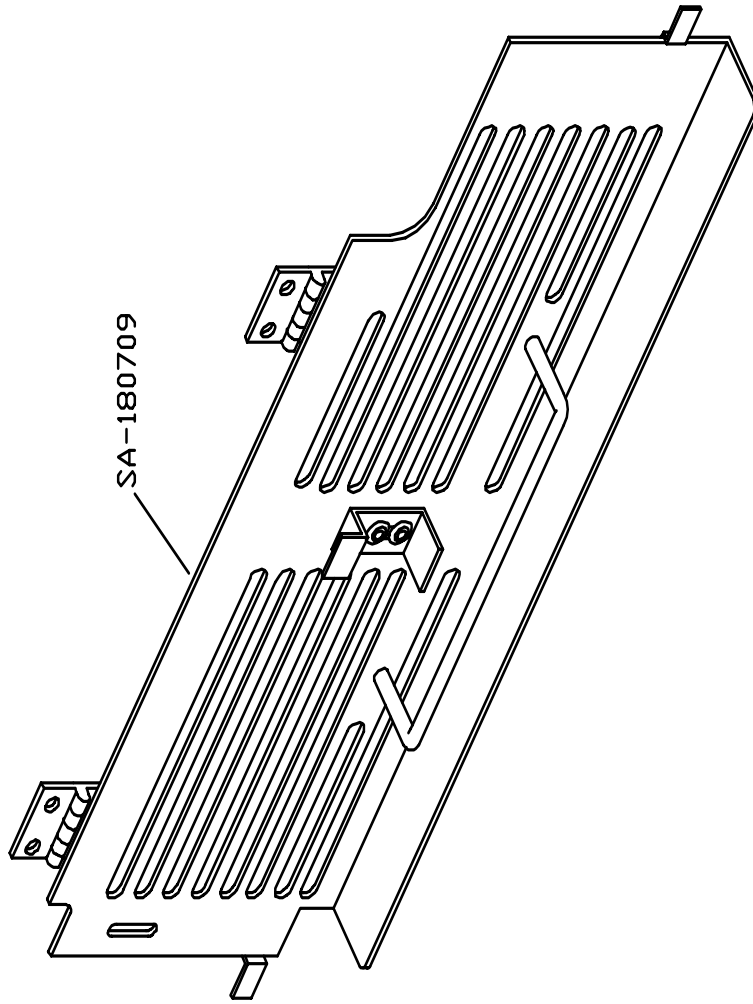

AB DICK 8800 PLATE CYLINDER GUARD ASSEMBLY

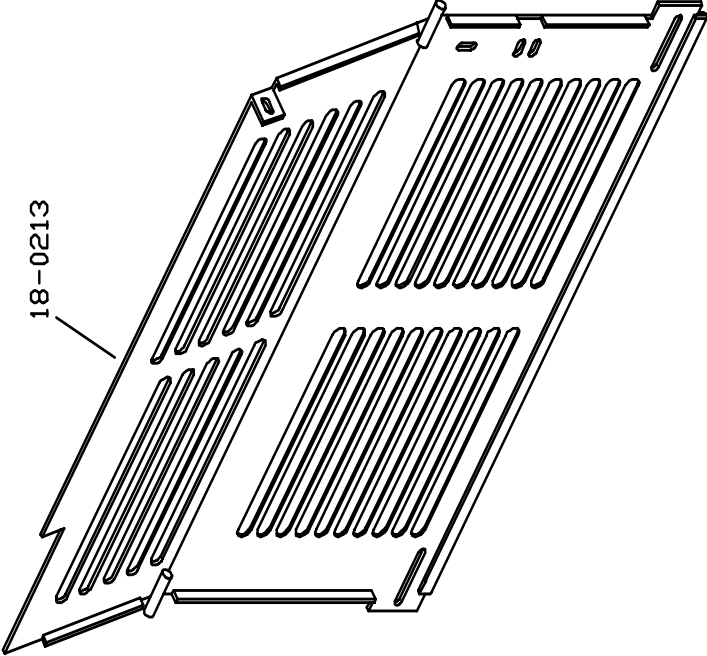

8800C16, 3-6-97

DAMPENER AND INKER GUARD ASSEMBLY  
AB DICK 8800

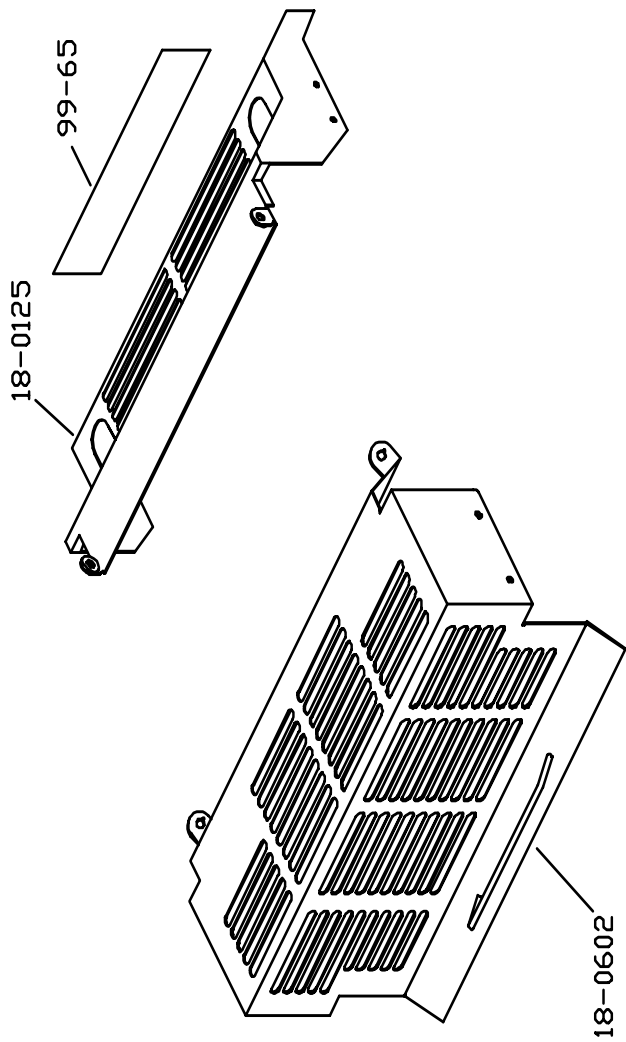

AB DICK 9800-9900 OPS SIDE FRAME ASSEMBLY

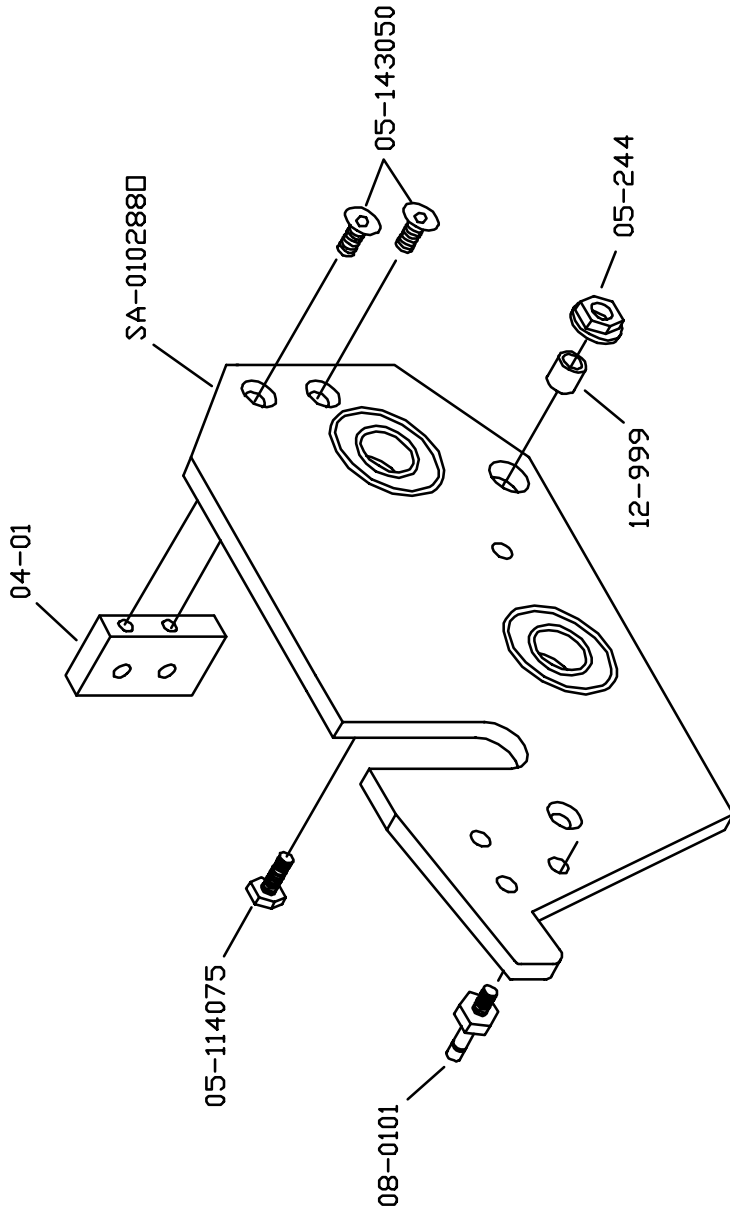

9800C01, 1-27-97

AB DICK 9800-9900 NOPS SIDE FRAME ASSEMBLY

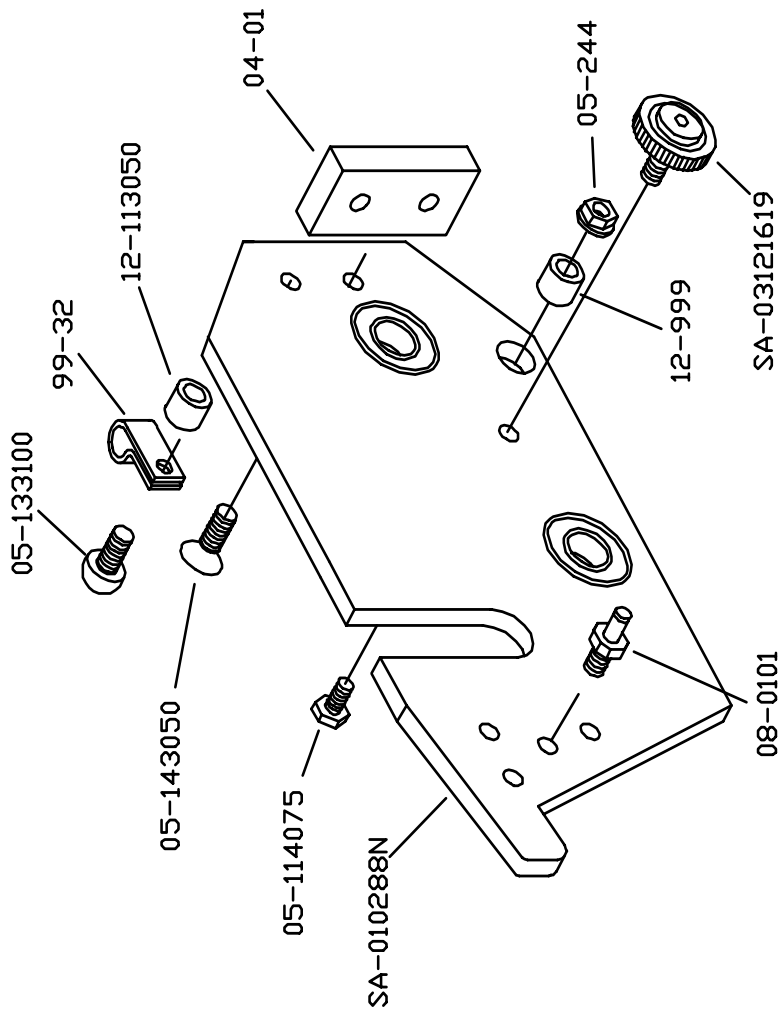

AB DICK 9800-9900 PAN ROLL/HANGER ASSEMBLY

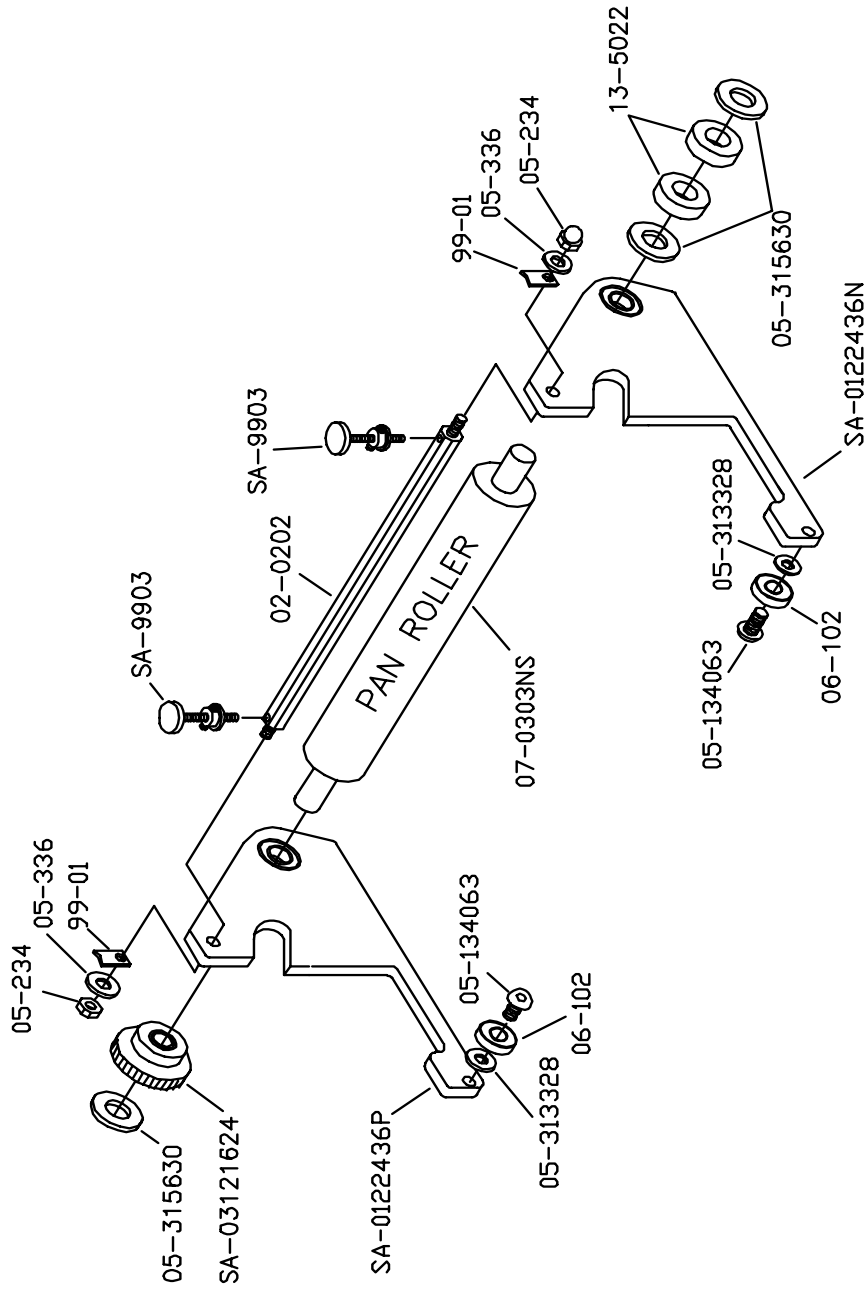

9800C05, 1-27-97

AB DICK 9800-9900 FORM ROLLER ASSEMBLY

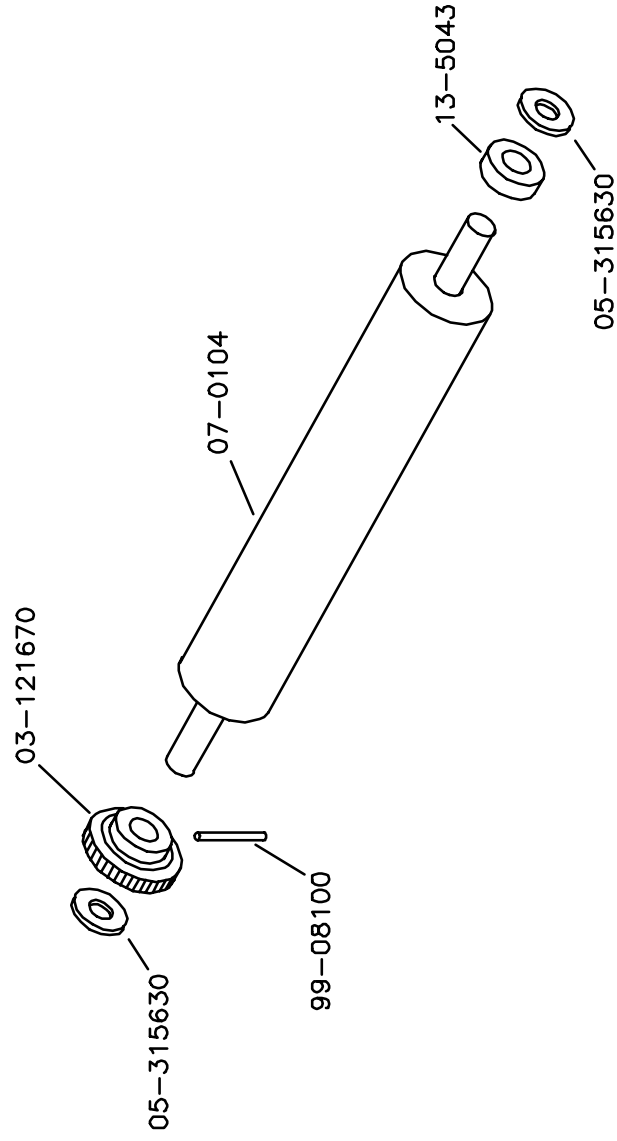



AB DICK 9800-9900 DAMPENER ASSEMBLY

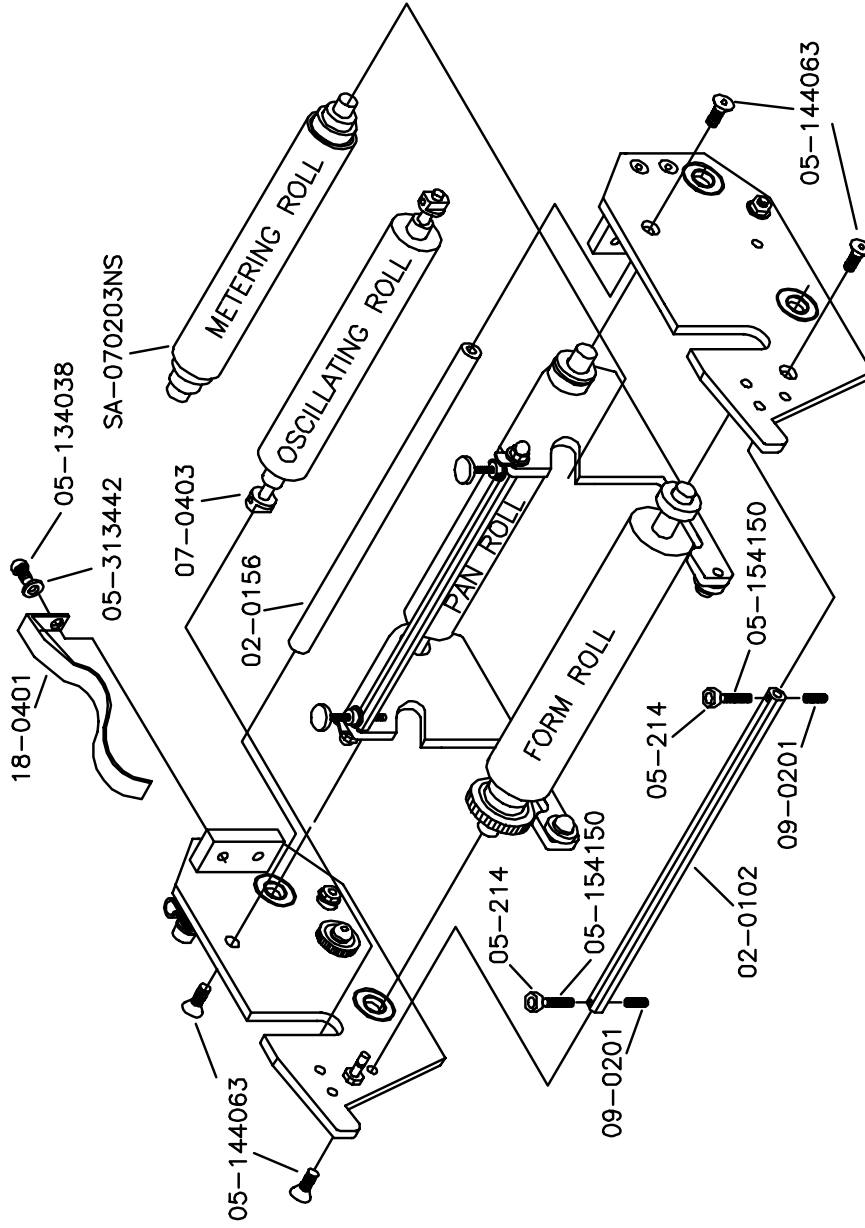

9800C07, 1-27-97

AB DICK 9800-9900 WATER PAN ASSEMBLY

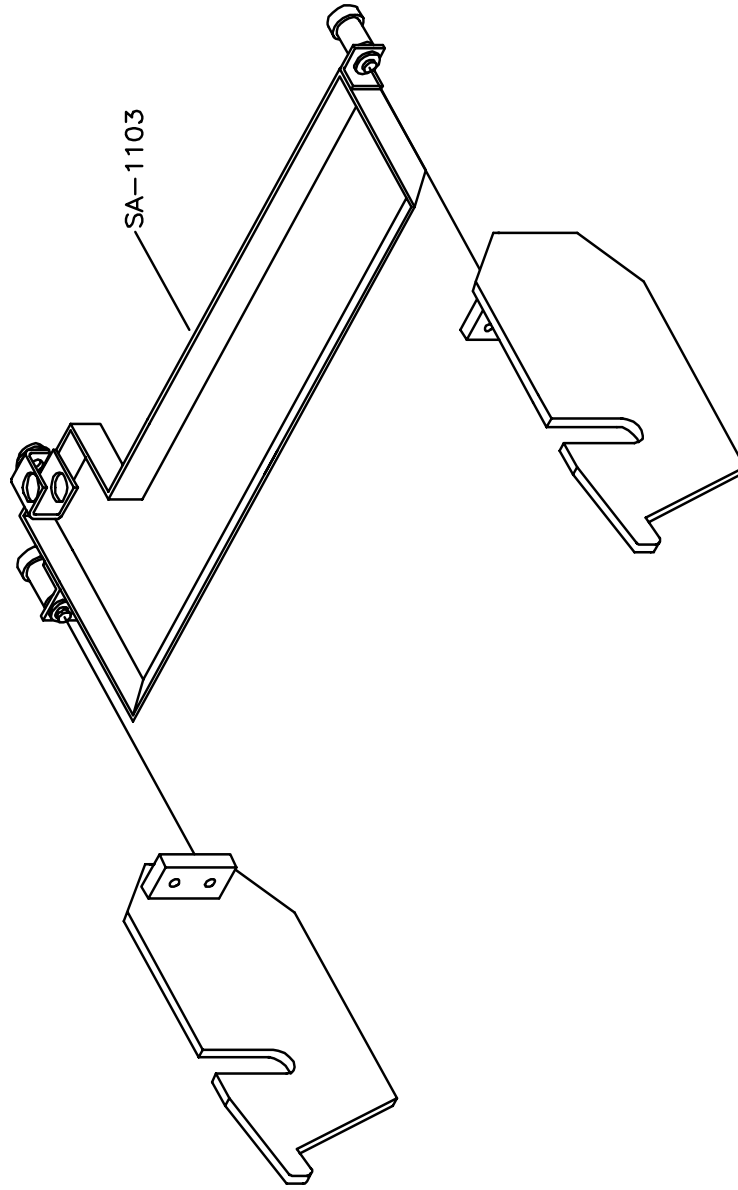

9800C08, 1-27-97

PLATE CYLINDER GUARD MOUNTING HARDWARE  
AB DICK 9800-9870

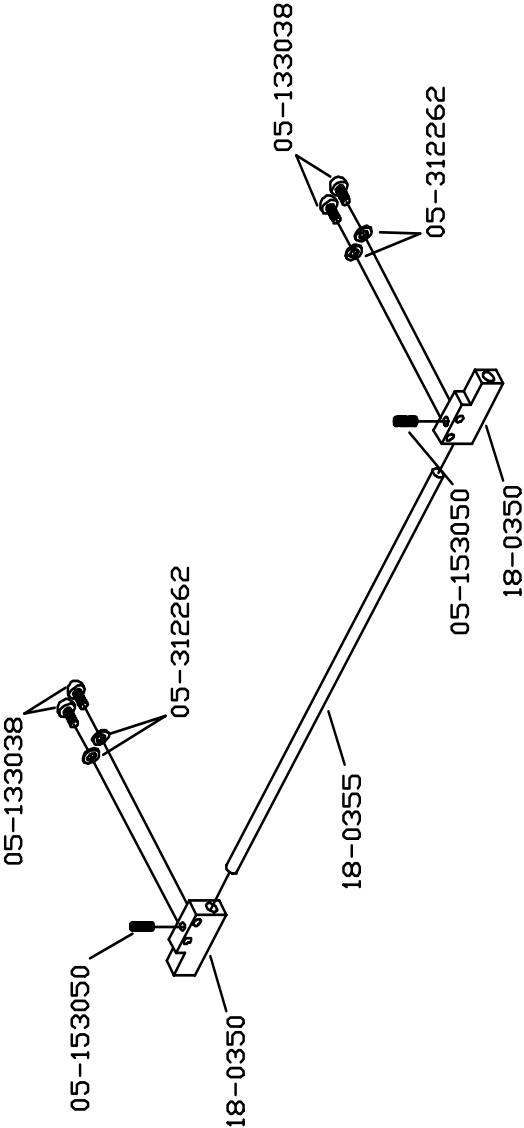

DAMPENER AND INKER GUARD MOUNTING HARDWARE  
AB DICK 9800-9850

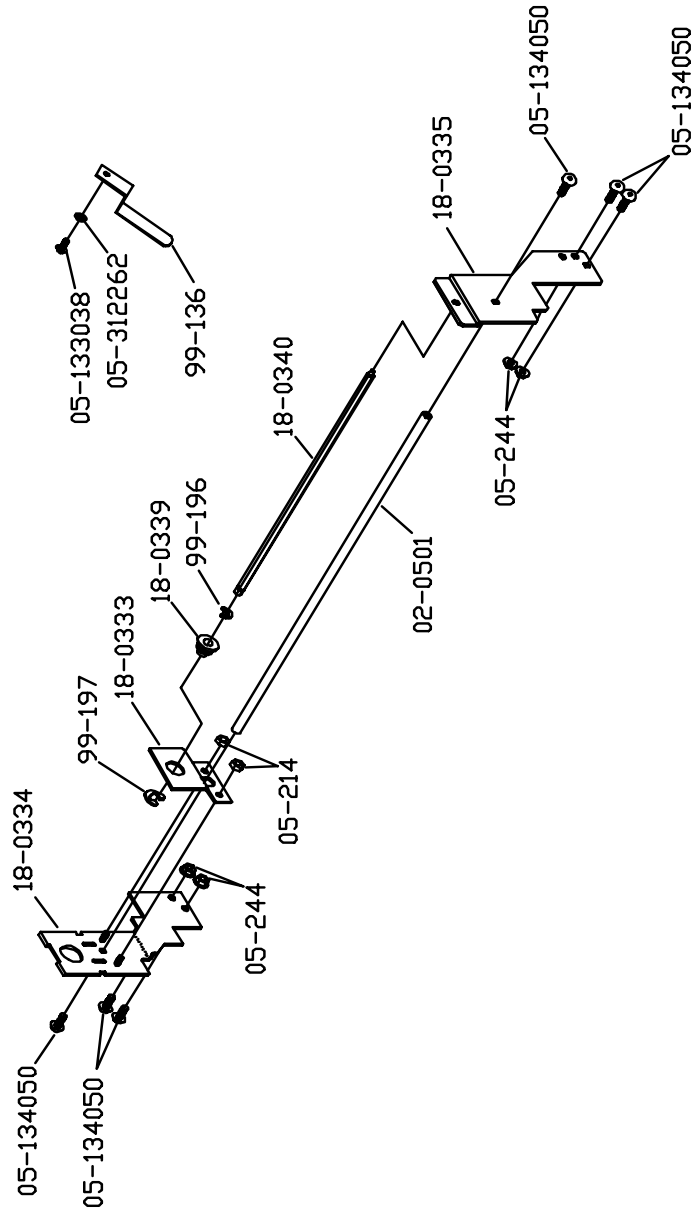

AB DICK 9800-9900 ACTIVATION ASSEMBLY

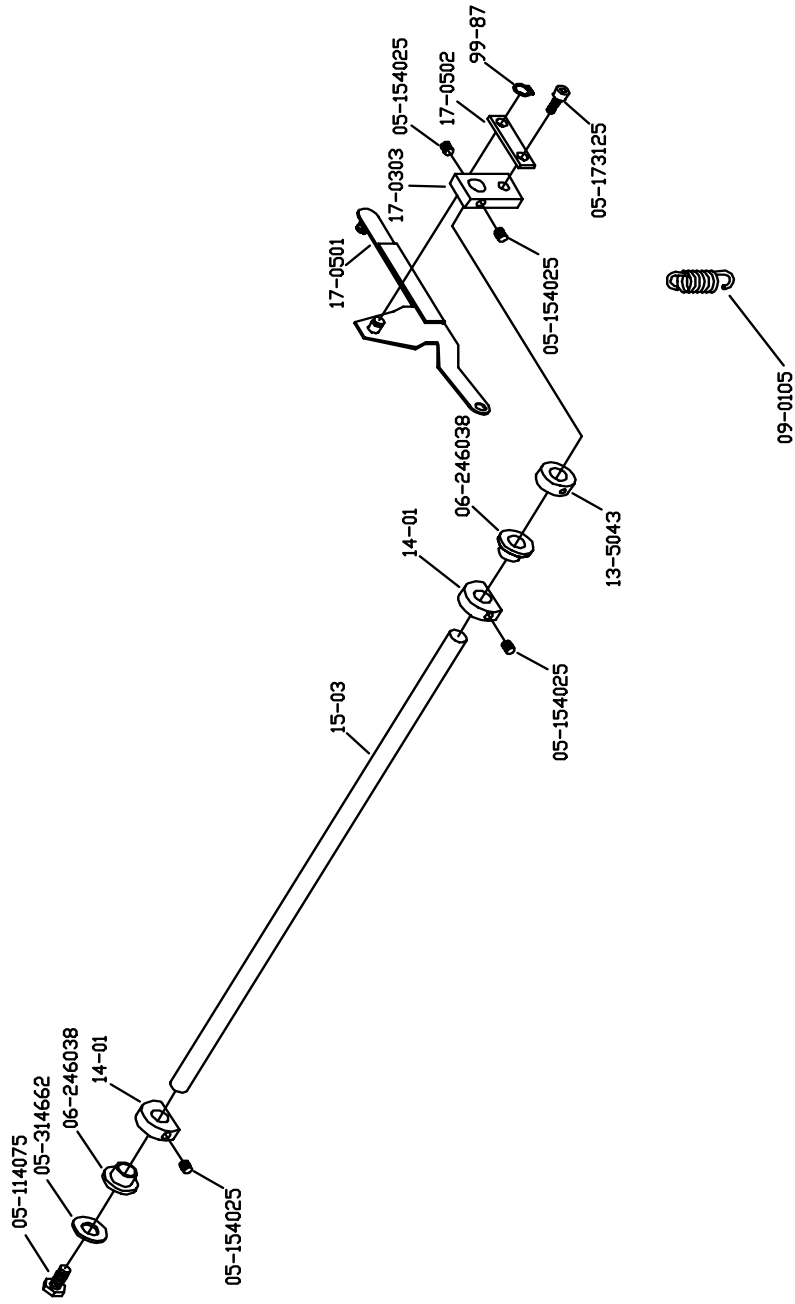

9800C11, 1-27-97

AB DICK 9800-9900 STRIPE ADJUSTMENT ASSEMBLY

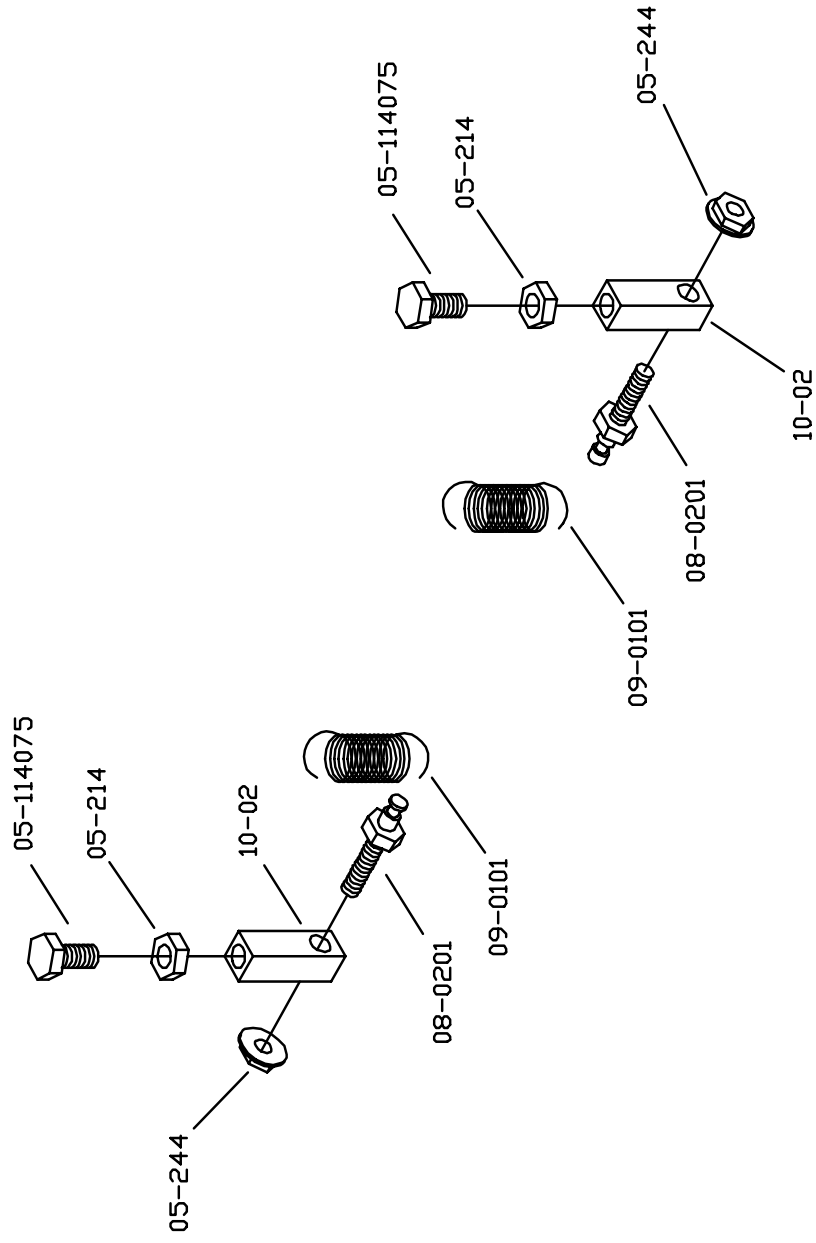

SUPER T-HEAD GUARD ASSEMBLY  
AB DICK 9800-9900

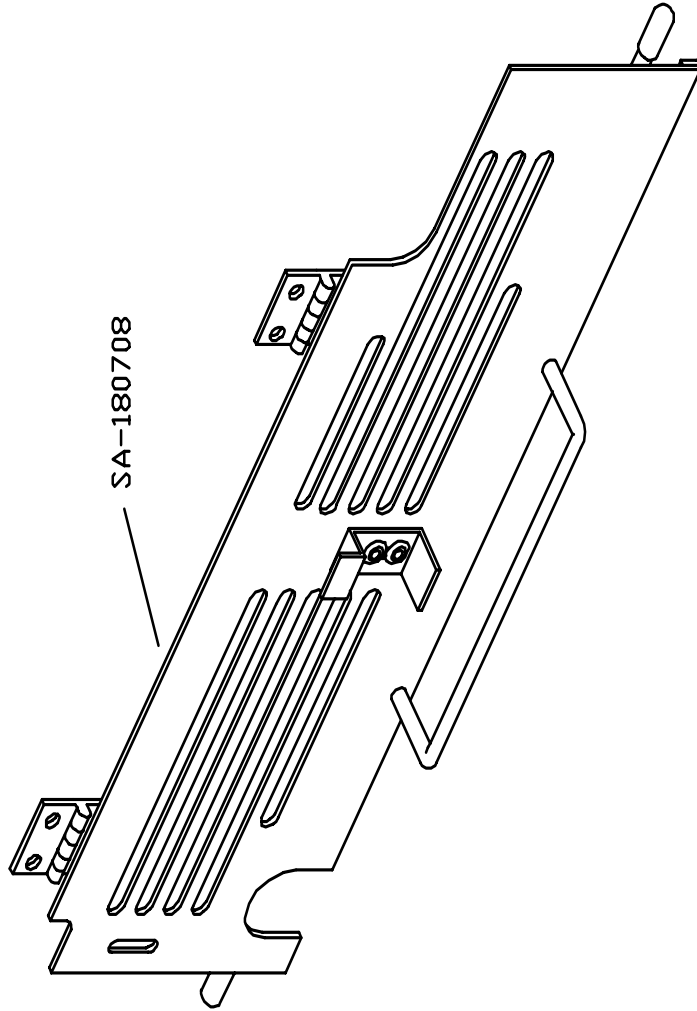

9800C13, 3-6-97

T-HEAD GUARD ASSEMBLY  
AB DICK 9800-9900

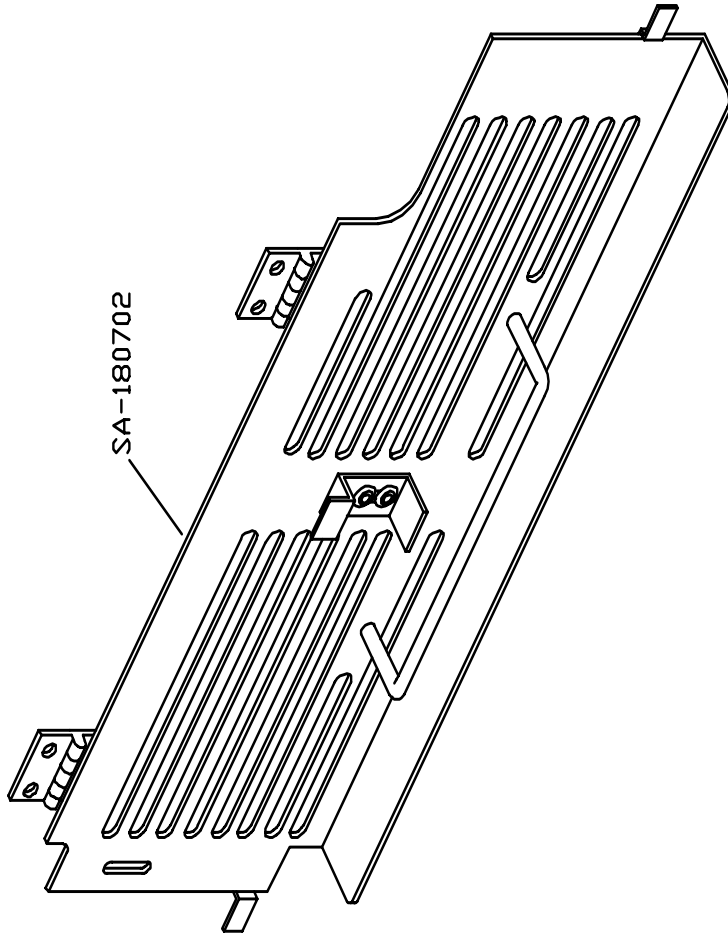

9800C14, 3-6-97



DAMPENER AND INKER GUARD ASSEMBLY  
AB DICK 9800-9870

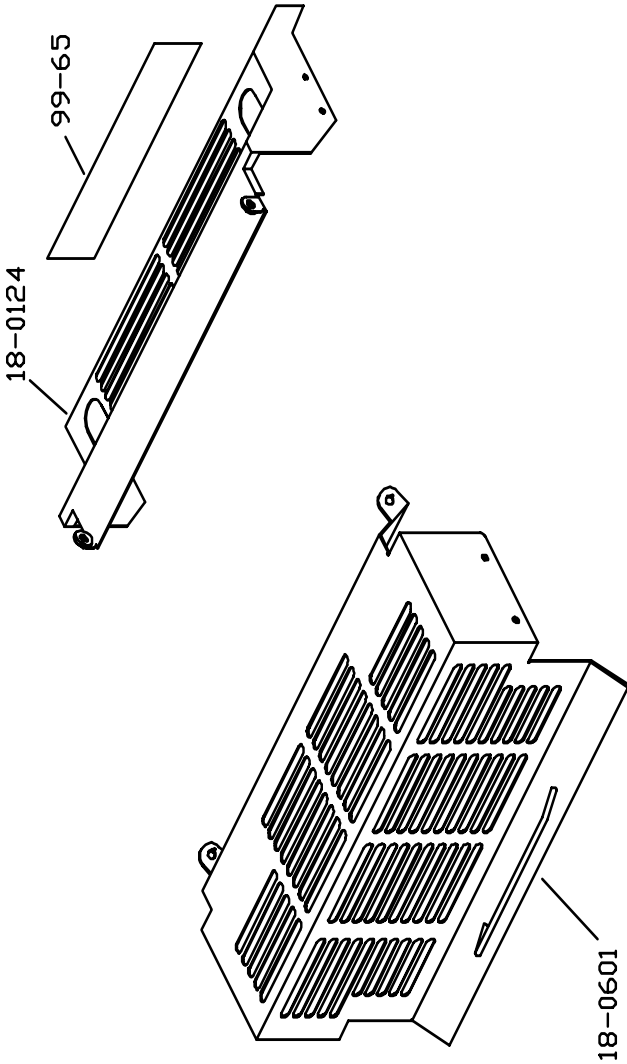

9800C15, 3-6-97

PLATE CYLINDER GUARD ASSEMBLY  
AB DICK 9800-9870

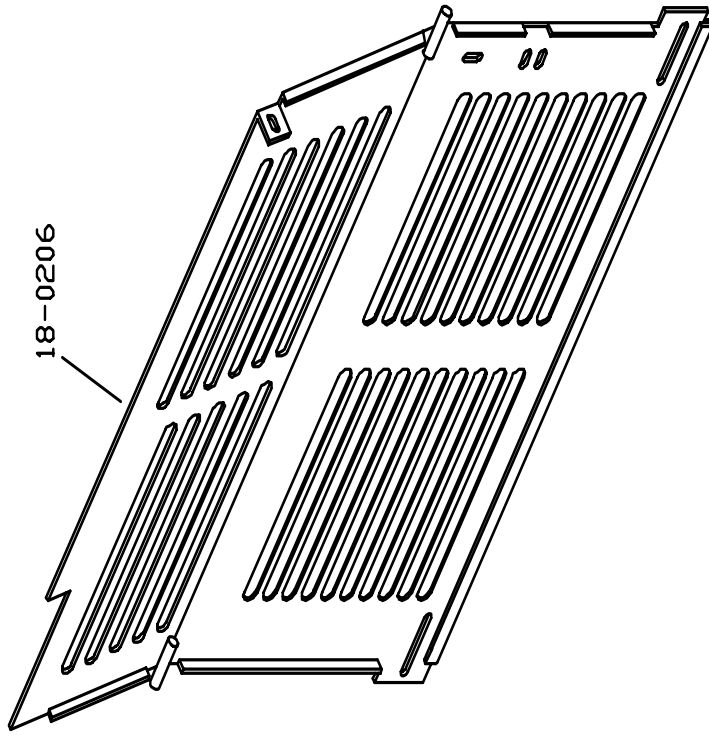

WATER BOTTLE ASSEMBLY  
AB DICK 9800

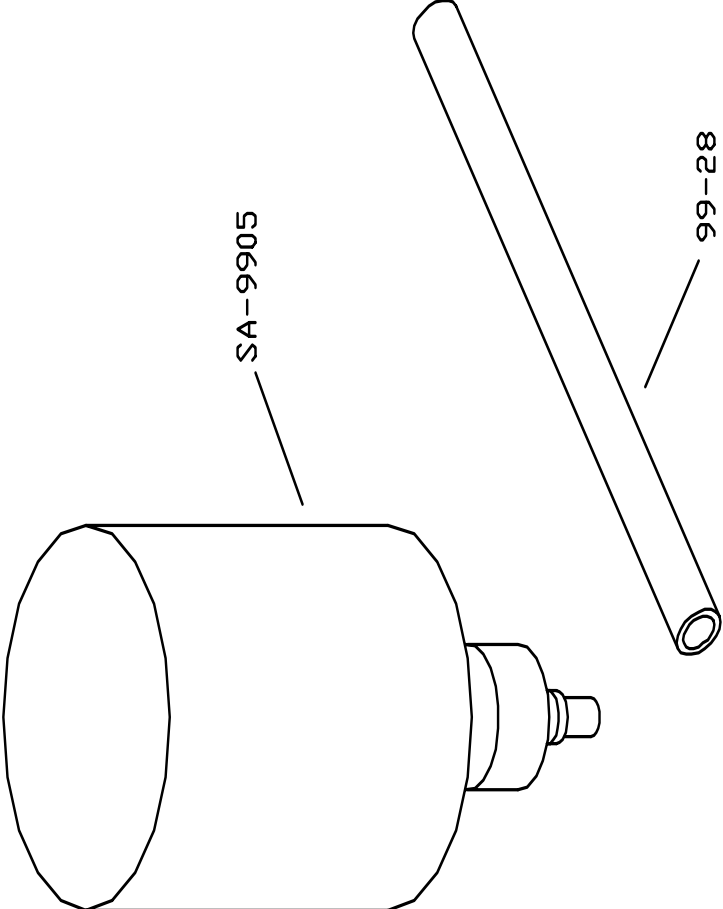

9800C17, 3-6-97

PLATE GUARD ASSEMBLY  
AB DICK 9900

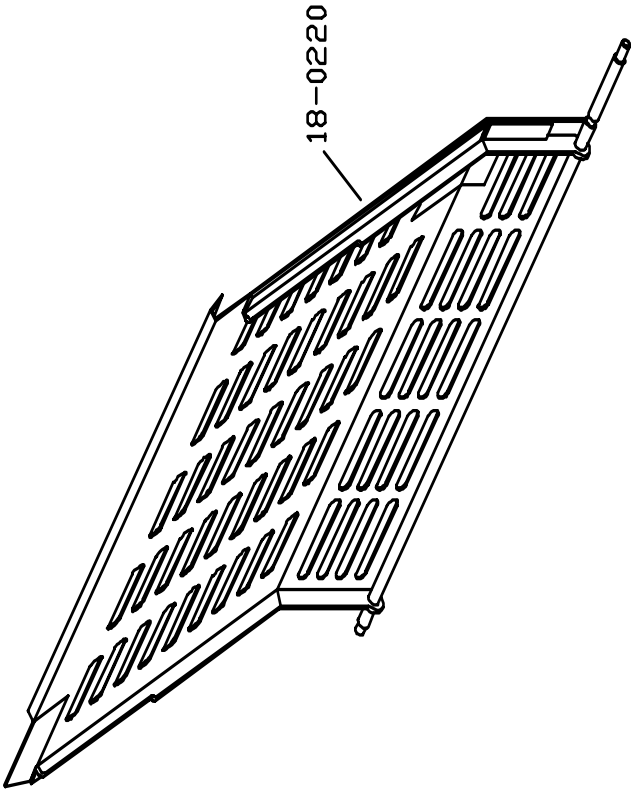

DAMPENER AND INKER GUARD MOUNTING HARDWARE  
 AB DICK 9900

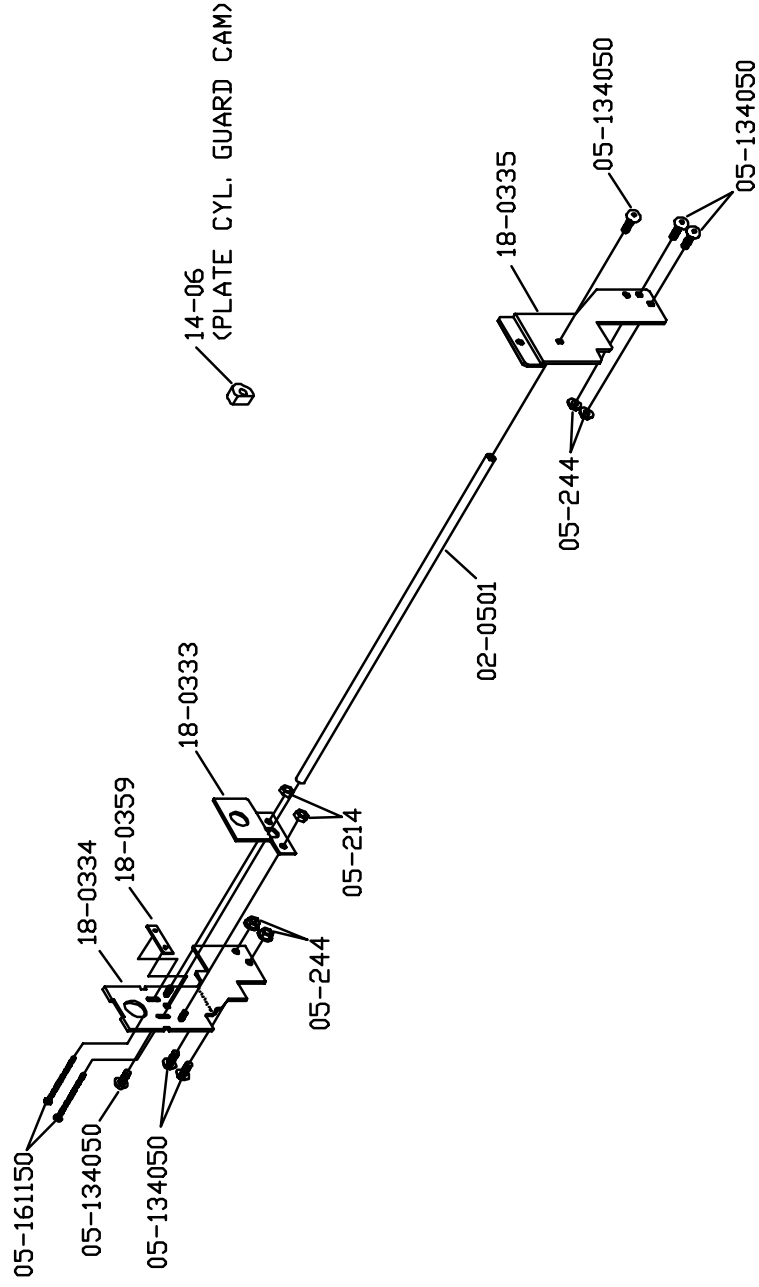

9900C02, 3-6-97

DAMPENER GUARD ASSEMBLY  
AB DICK 9900

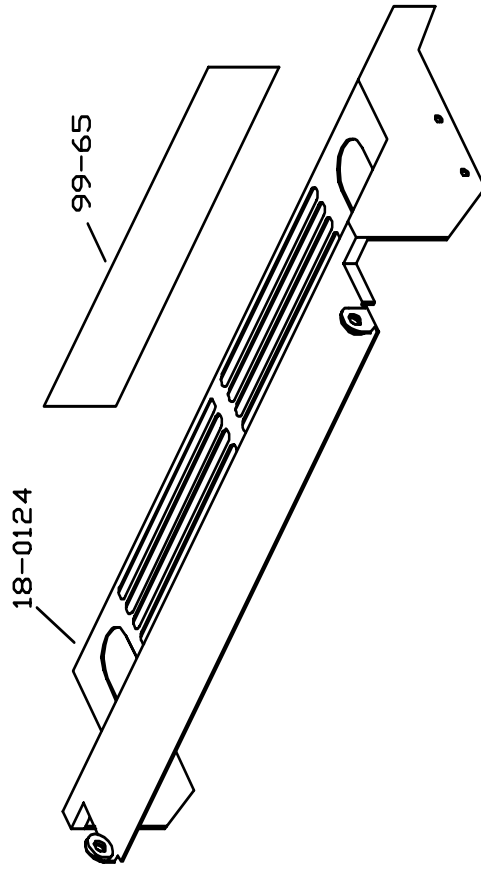









*A Pamarco Technologies Inc. Company*

11103 Indian Trail, Dallas, TX 75229 Phone 972-484-6808, Fax 800-365-6510  
E-mail [info@accel-us.com](mailto:info@accel-us.com), Web Site [www.accel-us.com](http://www.accel-us.com)