

# **Crestline<sup>®</sup> Dampening System**

## **Installation Instructions**

**Hamada RS34 & VS34**

**Satellite Unit**

**For Presses Originally Equipped With  
Integrated Dampeners**



*A Pamarco Technologies Inc. Company*

X88-113  
01/2001  
Rev-A

# GENERAL INFORMATION

## **ATTENTION CRESTLINE® DAMPENER OWNER!**

Accel Graphic Systems provides parts and service through its authorized distributors and dealers. Therefore, all requests for parts and service should be directed to your local dealer.

The philosophy of Accel Graphic Systems is to continually improve all of its products. Written notices of changes and improvements are sent to Accel Graphic Systems' Dealers.

If the operating characteristics or the appearance of your product differs from those described in this manual, please contact your local Accel Graphic Systems Dealer for updated information and assistance.

Always update your dampener when improvements are made available, especially those related to safety.

### **YOUR AUTHORIZED CRESTLINE® DEALER IS:**

---

---

---

---

### **THE SERIAL NUMBER OF YOUR CRESTLINE® DAMPENER(S) IS:**

---

---

## **SAFETY INFORMATION**

**FOR YOUR SAFETY, DO NOT DISENGAGE OR REMOVE ANY GUARDS FROM THE CRESTLINE® DAMPENER. THE DAMPENER CONTAINS SOME INWARD ROTATING ROLLER NIPS THAT CAN CAUSE INJURY IF LEFT UNGUARDED.**

# GENERAL INFORMATION

## BASIC CONFIGURATION OF CRESTLINE®

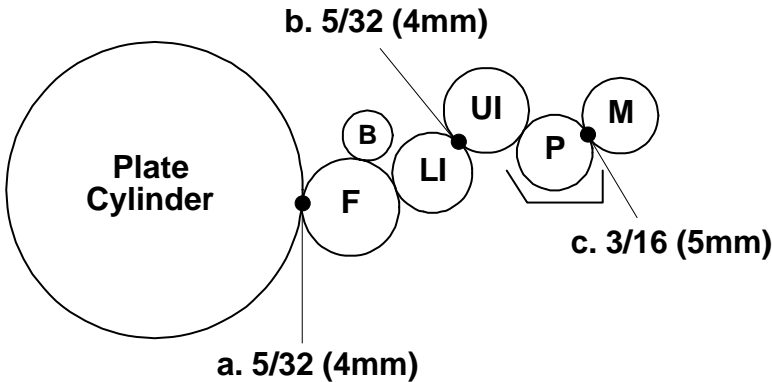

**Adjustments**  
 a. Form to Plate  
 b. Upper Intermediate to Lower Intermediate  
 c. Metering to Pan

**Roller Descriptions**  
**F** = Form  
**B** = Oscillator/Bridge  
**LI** = Lower Intermediate  
**UI** = Upper Intermediate  
**P** = Pan  
**M** = Metering

**TERMINOLOGY**    **OPS**            =    Operator's Side  
                               **NOPS**            =    Non Operator's Side

### TECHNICAL ASSISTANCE

For technical assistance during the installation, please contact:

**ACCEL GRAPHIC SYSTEMS**  
 11103 Indian Trail  
 Dallas, TX 75229  
 (972) 484-6808  
 FAX (800) 365-6510  
 E-MAIL [accel@dallas.net](mailto:accel@dallas.net)  
 WEB SITE [www.accelgraphicsystems.com](http://www.accelgraphicsystems.com)

Crestline® is covered by U.S. Patents and Patents Pending

# GENERAL INFORMATION

## REQUIRED TOOLS

1. Phillips Screwdriver
2. Standard Screwdriver
3. 8 mm Open End
4. 10 mm Open End
5. 13 mm Open End
6. 17 mm Open End
7. 2.5 mm Allen Wrench
8. 3 mm Allen Wrench
9. 4 mm Allen Wrench
10. 5 mm Allen Wrench
11. 2.5 mm Punch
12. 3.0 mm Punch
13. 5.0 mm Punch
14. Hammer
15. Snap Ring Pliers

# PRE-INSTALLATION INFORMATION

1. Cut the ties holding the rollers and examine rollers for gouges, scratches, or nicks.
2. Check box and parts board to make sure all pieces are present and nothing has broken in shipping.
3. Check the dampener for parallel. (Cutter bed works best.) If dampener rocks, it needs to be realigned. Loosen tie bar bolts at OPS and align the frames on the flat surface. Retighten bolts.

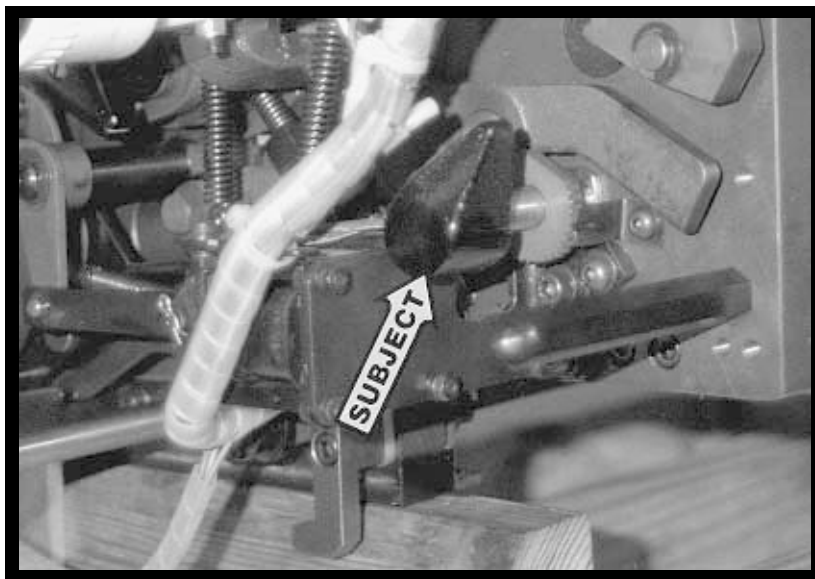
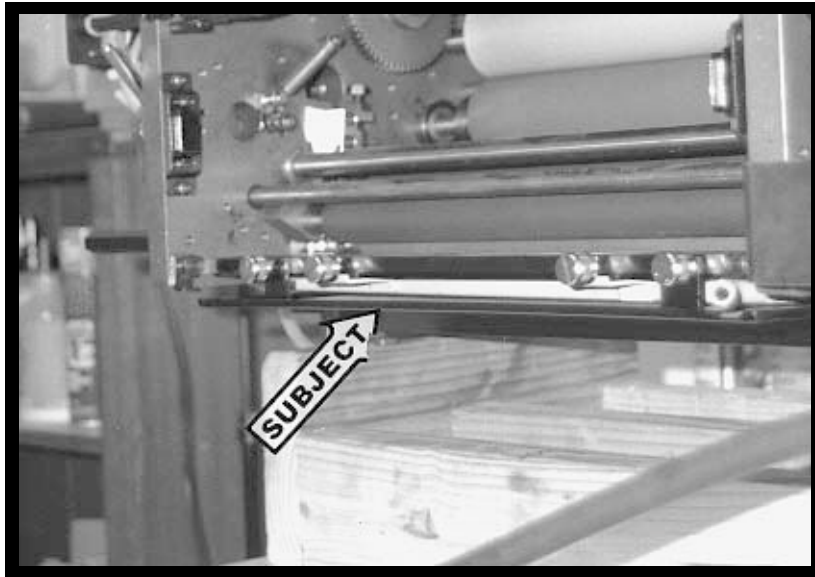
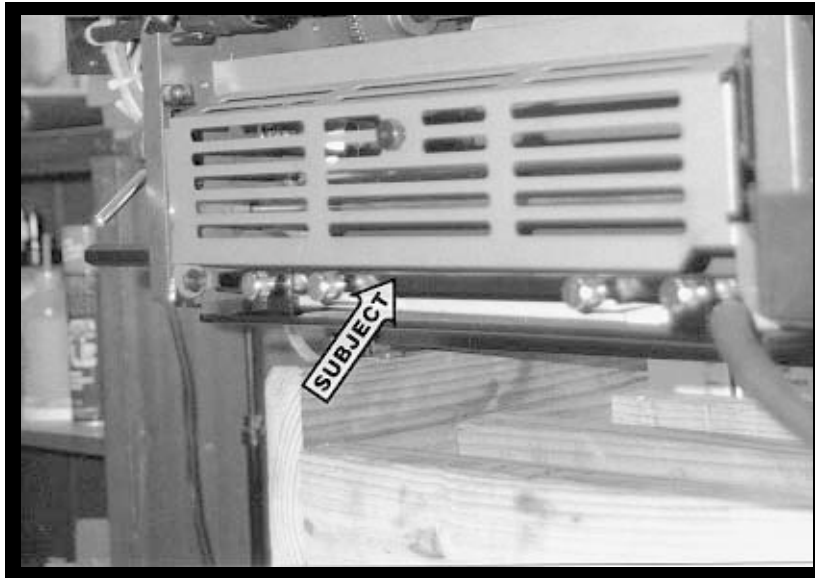

# DISASSEMBLY

**1**

Remove side covers and small guard, including magnet brackets, over original dampener. Save stud and nut on dampener guard.

---

**2**

Remove drip tray and water pan.

---

**3**

Pull out metering roller shaft and roller. Also, remove m.r. guide plates from frames, clicker plate, and bushing retainer.

**7**

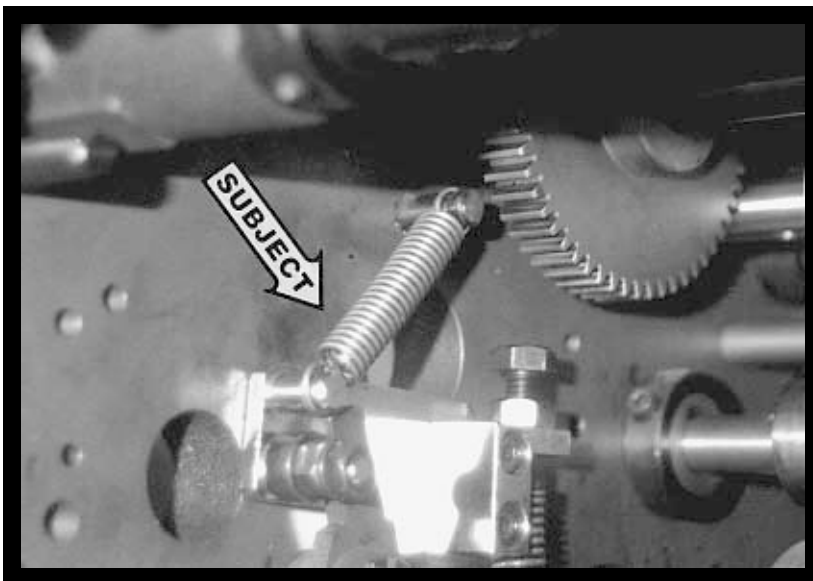
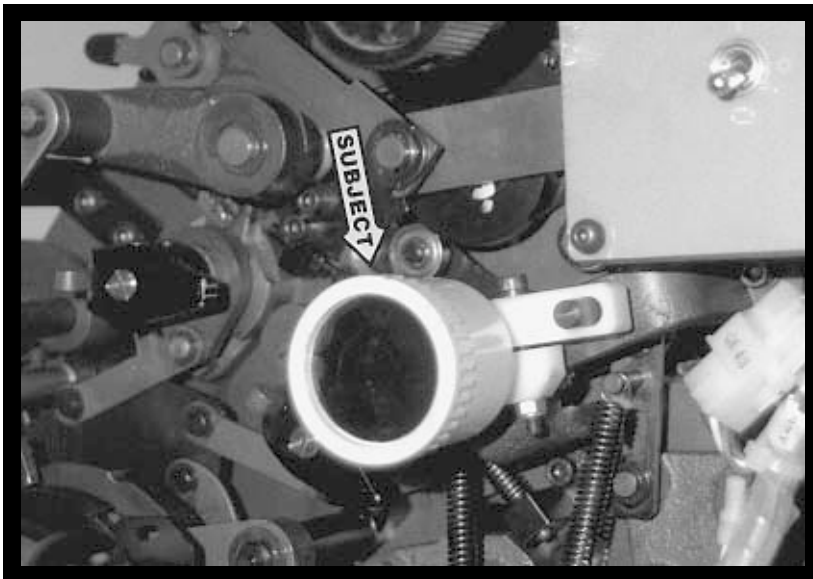
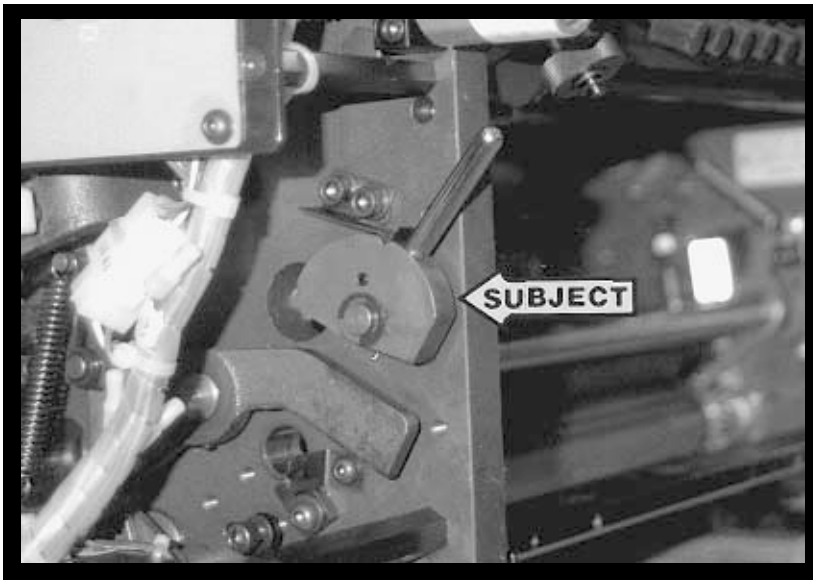



# DISASSEMBLY

**4**

Remove lockout assembly at OPS.

---

**5**

Remove water adjustment knob, tension block, and then the rest of the adjustment assembly.

---

**6**

Remove extension springs, compression spring blocks, frame, and transfer roller assembly. Knock out pins from all arms, disengage snap rings, and pull out shaft through OPS.

**9**

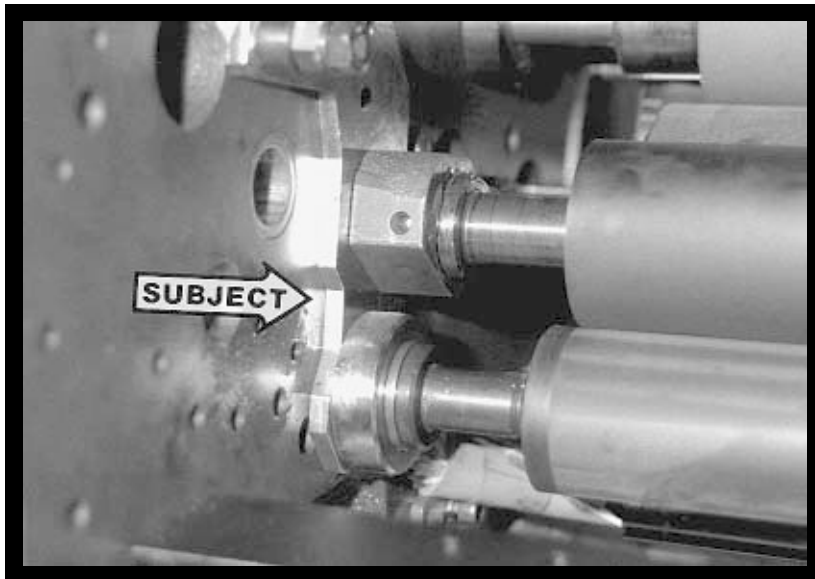
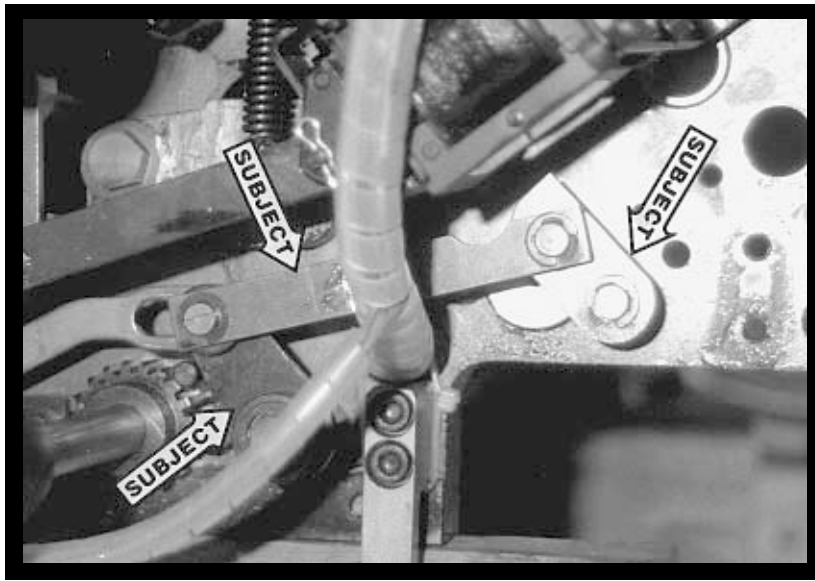

## DISASSEMBLY

**7**

Remove water linkage at OPS as indicated by arrows. It is helpful to temporarily disconnect solenoid assembly to provide easier access.

---

**8**

Remove bronze bushings at OPS & NOPS on pan roller and remove roller. Next, loosen set screws near transfer roller and remove studs. The entire transfer roller assembly can then be removed.

---

**9**

Temporarily remove the #1 ink form roller, and then remove water oscillator and water oscillator brackets at OPS & NOPS.

**11**

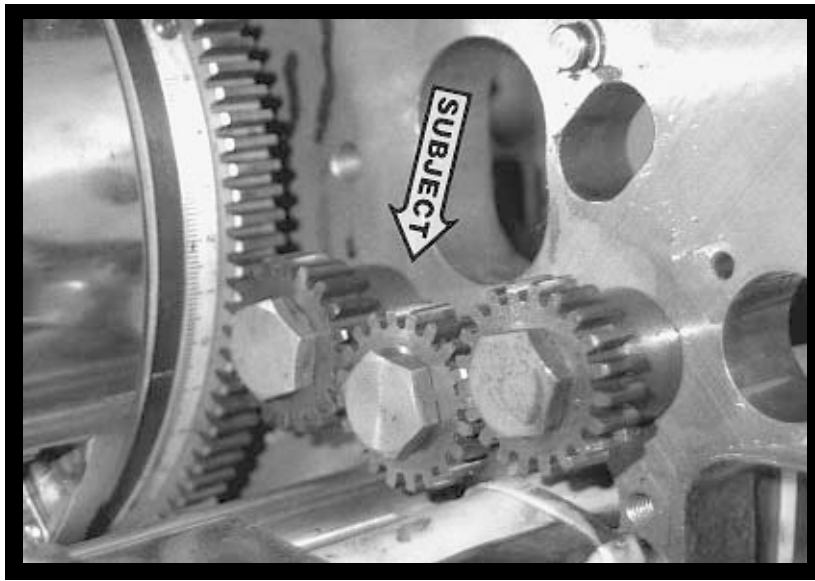

**10**

Remove idler gear train at NOPS.

---

**11**

Remove lower tie bar.

---

**13**

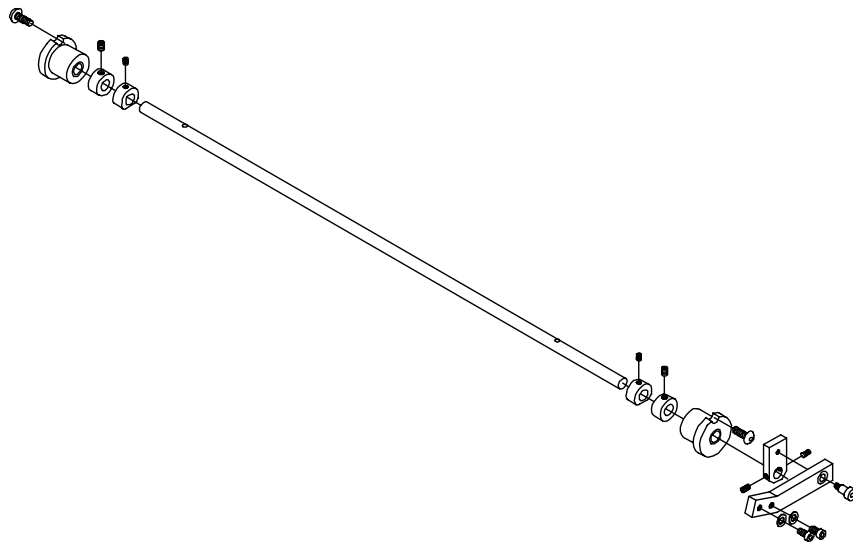
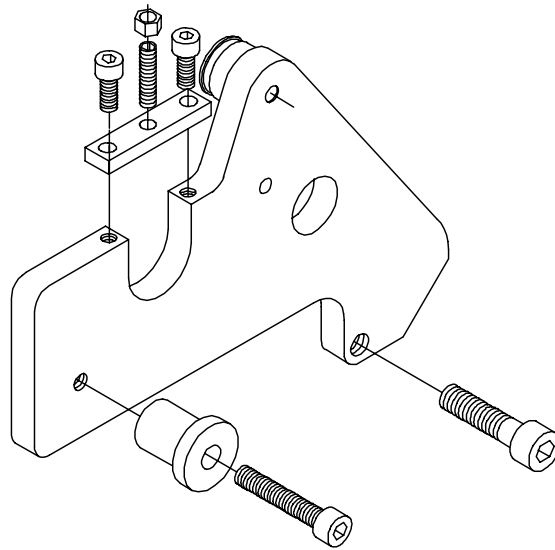
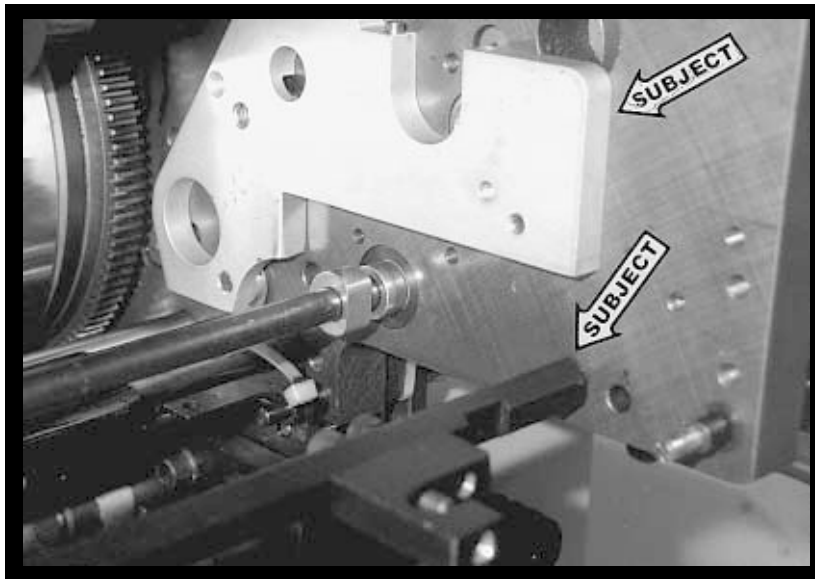

# INSTALLATION

**1**

Install tie bar (lower subject arrow) into common holes in press frames as shown. Note position of water pan mounting blocks.

---

**2**

Install mounting frames at OPS & NOPS using the provided spools and hardware as shown (see upper subject arrow in step 1).

---

**3**

Remove the NOPS shaft bushing. Insert the lift shaft assembly into the press frame through the OPS. Retain the bushing at the OPS and NOPS with the screw provided. Push the lift shaft through the NOPS shaft bushing until it is flush with the outside. Push the set collars up against the lift shaft bushing and tighten. The shaft should rotate freely and be centered between press frames.

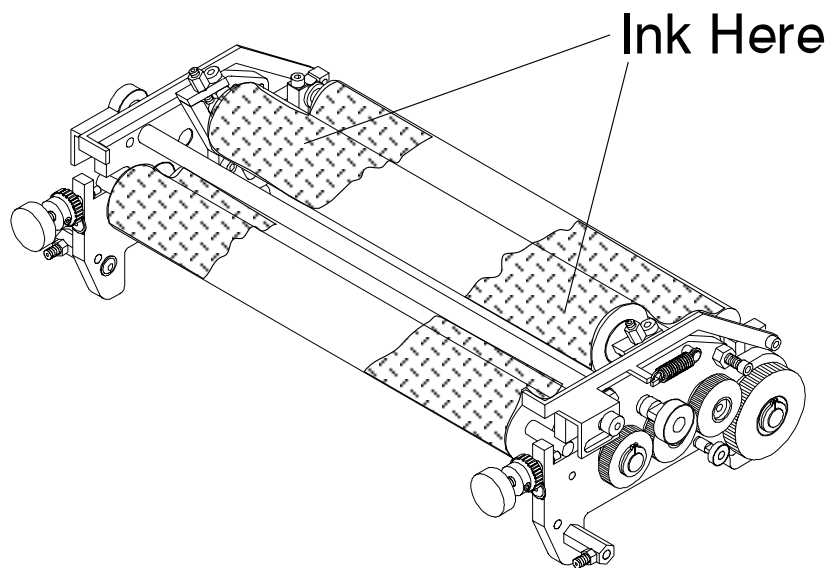
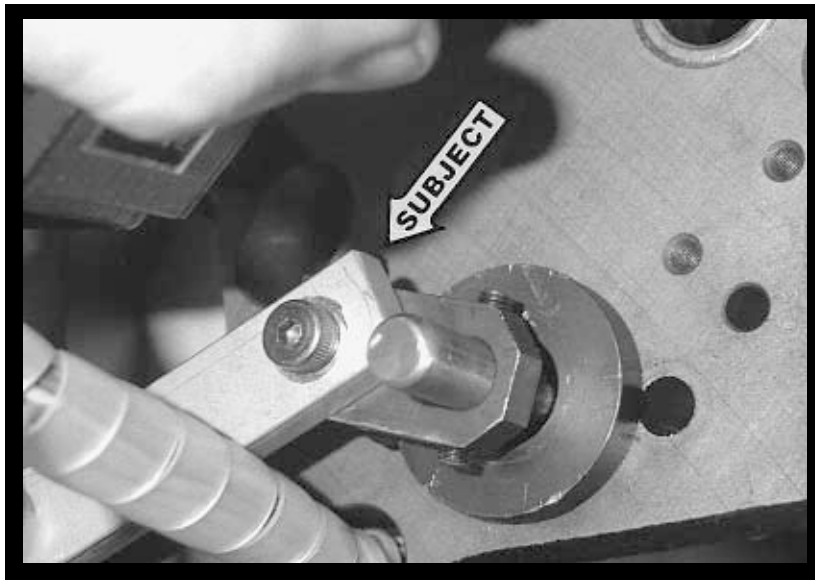



**4**

At OPS, slip control block over end of lift shaft and install arm extension onto the slot in the original Hamada water form link using the provided bolts and washers.

---

**5**

Reinstall solenoid assembly which was temporarily disconnected in disassembly step 7.

---

**6**

### **OPTIONAL SHORTCUT**

Check dampener for square on cutter bed or flat surface. Apply ink to left and right third of oscillator roller, leaving center third clean (see drawing). Roll dampener by hand to smooth ink. You can adjust all the roller stripes on the table where it is easier to see, rather than when it is in the press. See Final Adjustments section for roller setting instructions. After setting stripes, return to Installation step 7.

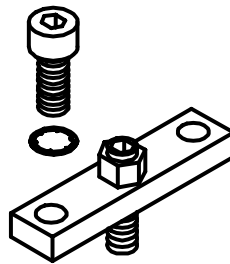
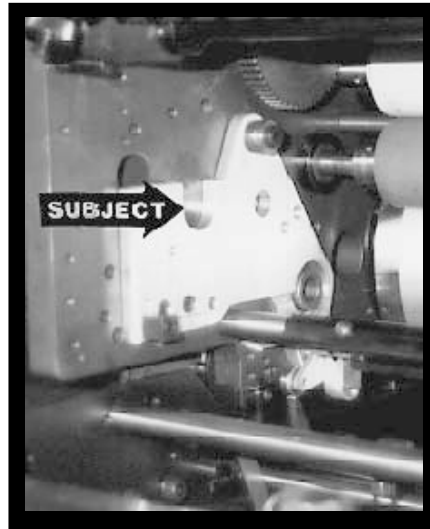
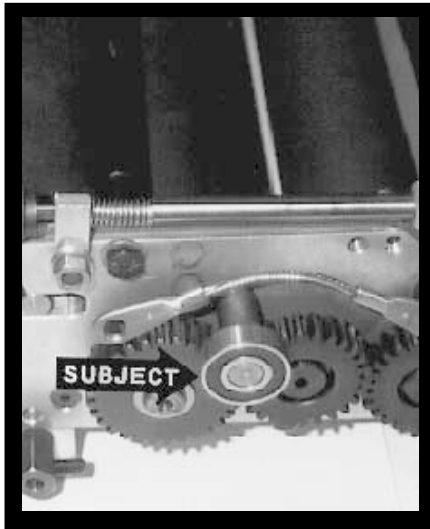
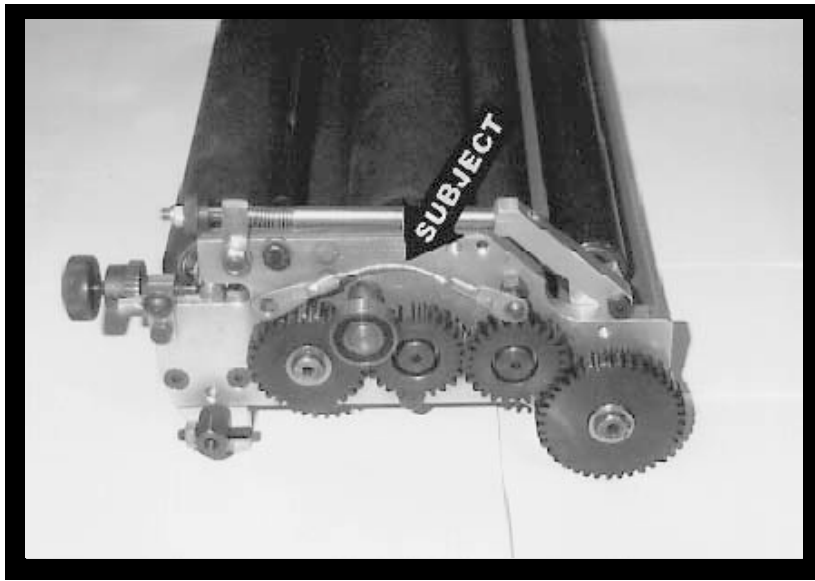

7

Make sure cable is attached as shown (subject arrow) and hanging loosely over the pivot studs.

**NOTE: Be sure that the bridge roller is locked in the unbridged position.**

8

Place single lever into the "Ink On" position and put dampener in the press so the bearings (subject arrow, left hand picture) rest in the mounting frame cradles (subject arrow, right hand picture).

9

Install bearing caps to hold dampener in place (subject arrow).

**Do not adjust the center screw in the middle of the cap, it is preset for the proper tension at the factory.**

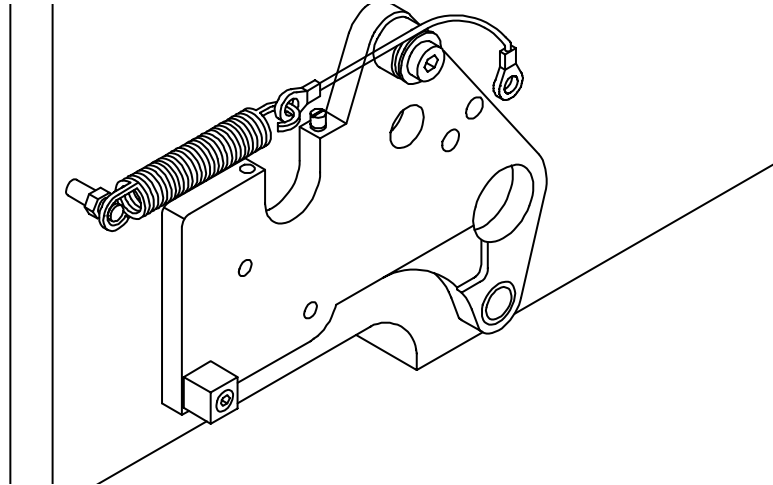
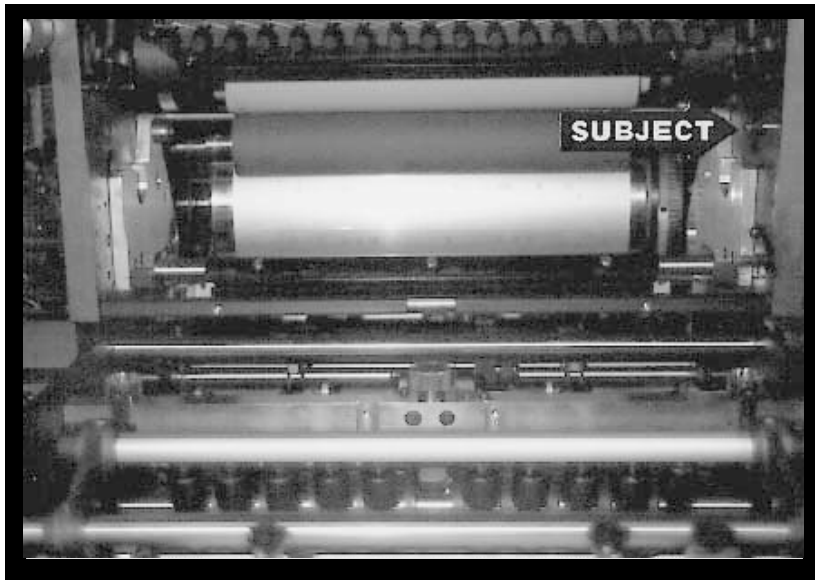

**10**

Install spring studs in satellite head frame (subject arrow).

---

**11**

Place cables over brass pulleys. Attach springs to cables & studs, making sure cable is in the groove of the brass pulleys.

---

**12**

Rotate head using manual knob to check gear mesh between the form gear and plate cylinder gear.

Install the tie bar.

**21**

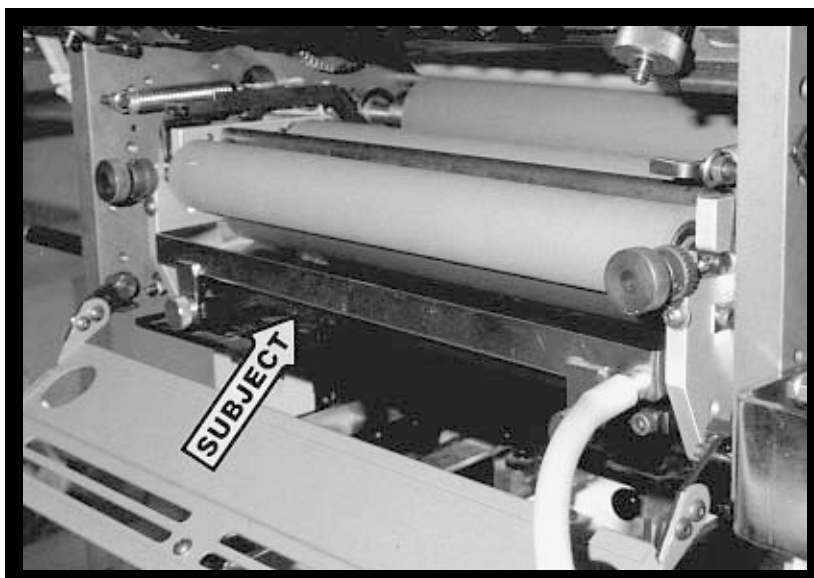
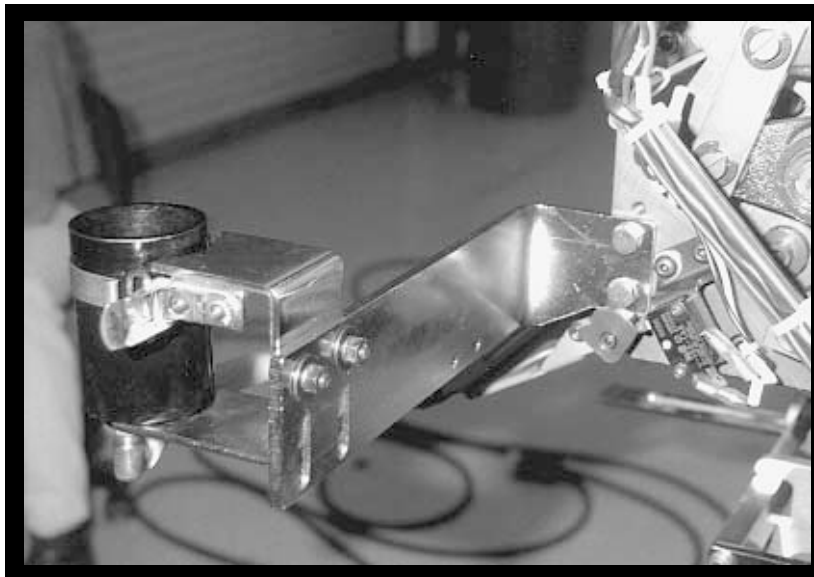
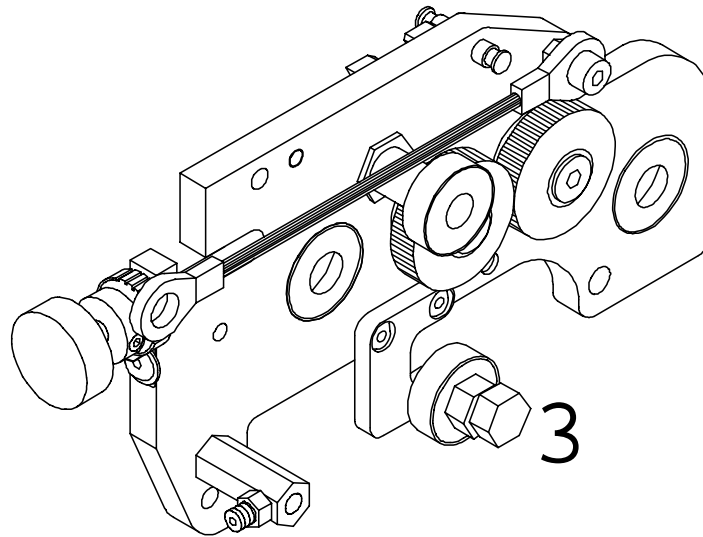

**13**

Return press lever to "0" position. The dampener form roller should separate from the plate cylinder by 1 to 1.5 mm. To adjust, rotate the eccentrics (subject arrow) on each side of the dampener while observing the gap. Fully tighten lock bolts in eccentrics when finished.

---

**14**

Replace original water bottle bracket with new one provided.

---

**15**

Attach water pan and drip tray to the blocks on the tie bar. Check that the pan itself is level and rotate tie bar to adjust if necessary. Replace original guard with new one provided.

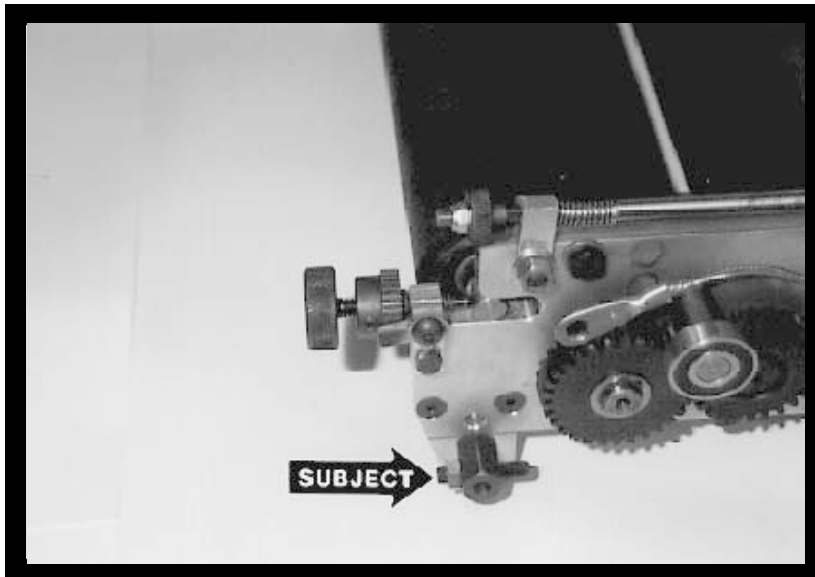



# FINAL ADJUSTMENTS

1

Place press lever in the number 1 (water on) position. Rotate dampener lift shaft so that the flats of the cams are just touching the bearings on the dampener. In this position, tighten control block to lift shaft.

**NOTE:** If the lift cams are not centered to the dampener bearings, then it may be necessary to recenter the shaft.

Dab ink on the dampener on a hard roller and turn the press by hand at first to distribute the ink. Slowly jog and run the press until the ink is distributed evenly on all the dampener rollers.

2

## Water Form to Plate

Drop the water form roller to the plate and check the stripe. It should be  $5/32$ " (4mm). Adjust the stripe using the stop screws on the dampener frame (subject arrow). **Turning the screw in decreases the stripe.** Lock in place using lock nut.

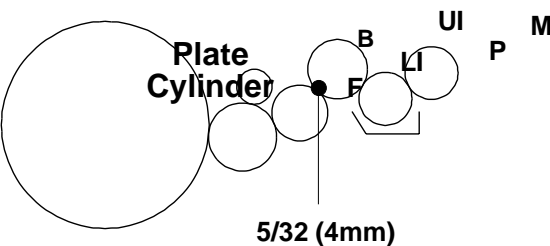

3

## Upper Intermediate to Lower Intermediate

Check the stripe between the upper intermediate & lower intermediate rollers by dropping the water form to the plate and rotating the press backwards (Clutches prevent dampener from turning backwards with the water form off the plate. Dropping the form to the plate allows the ink to drive the unit backwards.)

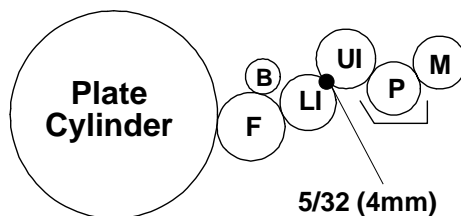

Stripe should be  $5/32$ " (4mm). Adjust by turning the screw on top of the hanger (subject arrow). **Turning the screw down increases the stripe.** Tighten lock nut when finished.

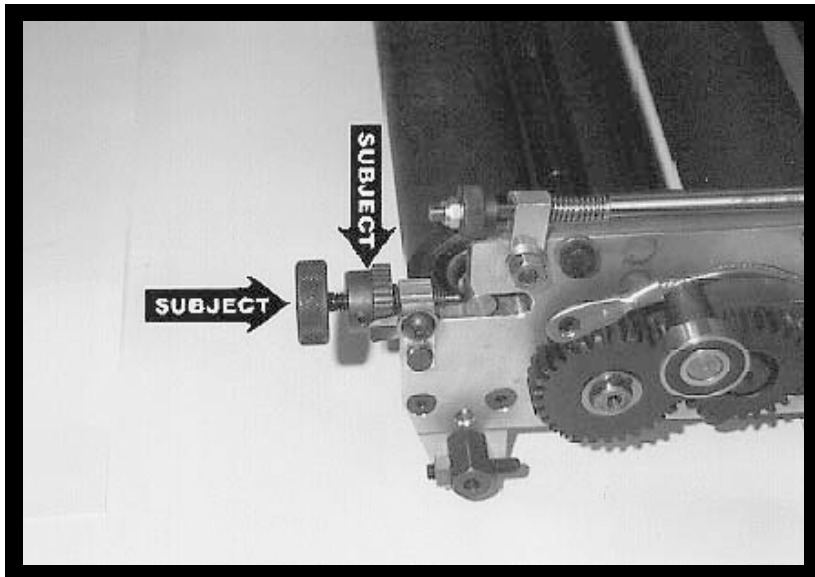

# FINAL ADJUSTMENTS

4

## Upper Intermediate to Pan

This pressure is set automatically when setting the intermediate to form in step 3.

5

## Metering to Pan

Jog the press forward and observe the stripe on the pan roller. It should be  $3/16"$  (4.5mm - 5mm). **Turn the knurled metering knobs (left subject arrow) clockwise to increase the stripe.**

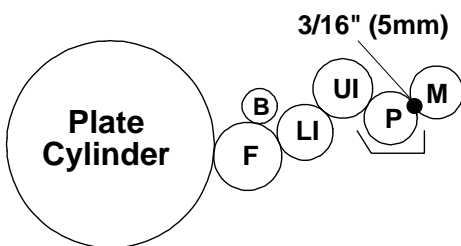

When the proper stripe has been obtained, spin the ratchet gears (right hand subject arrow) down until they bottom out on the stud and secure the ratchet gear to the knurled knobs with the set screws.

6

## Bridge to Water Form

Pressure between the bridge roller and water form is spring loaded and preset at factory.

### Water Pan Level

Adjust water level in pan by raising or lowering the original water bottle mechanism.

## BASIC OPERATION

### START OF DAY

- A. Make sure all the rollers are in place.
- B. Spin knurled knobs until the ratchet stops.
- C. Mount plate to cylinder. Wipe down all plates before running. Pre-ink the Crestline® dampener before running the plates with an extremely light coverage of ink by *engaging the bridge roller*. Bridge roller engages by pulling back and up on the bridge roller bracket to allow the roller to move toward the inker. To disengage, pull back and then down until the bracket notch rest on the shoulder bolt.
- D. Place water bottle in bracket.

**NOTE:** Accel recommends using the proper fountain solution for the plate material being run on the press. A good acid/gum etch should be used with metal plates.

---

### RUNNING DURING THE DAY

- A. In general, the Crestline® should not have to be adjusted from job to job. The form roller setting should never be changed unless it has deviated from the factory specification of 5/32" to the plate.
- B. Adjustments to the amount of water fed to the plate are made by the knurled knobs that apply pressure to the metering roller. The dampener has been set up for minimum water. To increase the water to the plate, turn the knurled knobs counter clockwise 1 or 2 clicks at a time. This opens the gap between the metering and pan rollers and allows more water to the plate.
- C. In general, more water will only be required when going from a metal plate to an electrostatic or Silvermaster type plate.

# CLEANING & MAINTENANCE

## WASH UPS DURING THE DAY

1. Remove bottle and drain the excess water from the pan.
2. Mount a metal plate to the press.
3. Turn on the press and squirt a small amount of press wash on the ink rollers.
4. Engage the bridge roller by rotating the levers at the OPS & NOPS towards the feed end of the press, dropping the bridge onto the ink form roller.
5. Use wash up attachment as normal. When the press is clean disengage bridge roller by pulling back on the levers until bearing on bridge roller drops into detent.
6. Remove water pan and clean any solution left in it.
7. Be sure to wipe excess clean up solution from the ends of the dampener metering and pan rollers.

---

## END OF THE DAY

1. Wash up press. Pay close attention to cleaning the ends of the pan and metering rollers that extend past the form rollers.
2. Spin the knurled knobs up until the metering roller can be removed.
3. Remove metering roller and wipe down thoroughly to remove any excess wash that may be on the roller.

## CLEANING & MAINTENANCE

### **DEGLAZING THE DAMPENER**

Periodic deglazing of water-soluble contaminants will be necessary with the Crestline®. Typically, once every 2-3 weeks will be sufficient, unless you are running electrostatic plates on a daily basis whereas deglazing should be performed weekly. A 50/50 solution of household ammonia and hot water can be used for deglazing purposes. If you prefer a commercially available deglazer, avoid those containing pumice or gritty substances. Always follow deglazing with straight water and then roller wash. Accel offers a product called **COMPOUND X** that we recommend for deglazing our system. Contact your dealer or Accel for more information.

---

### **OILING AND GREASING THE DAMPENER**

- A. Place a small amount of grease on the gears once a month.
- B. Inject grease into the oscillator grease fitting once a month.

# CLEANING & MAINTENANCE

## CRESTLINE® CLEANING & MAINTENANCE CHART

	Daily	Weekly	Bi-Weekly	Monthly
Wash Rollers	✓			
Deglaze Rollers				
Metal Plate Users			✓	
Silvermaster Plate Users			✓	
Electrostatic Plate Users		✓		
Grease Gears				✓
Inspect Ball Bearings				✓
Check Roller Pressures				✓
Check Roller Surfaces				✓

HAMADA RS/VIS 34 INTEGRATED SATELLITE  
SAFETY COVER ASSEMBLY

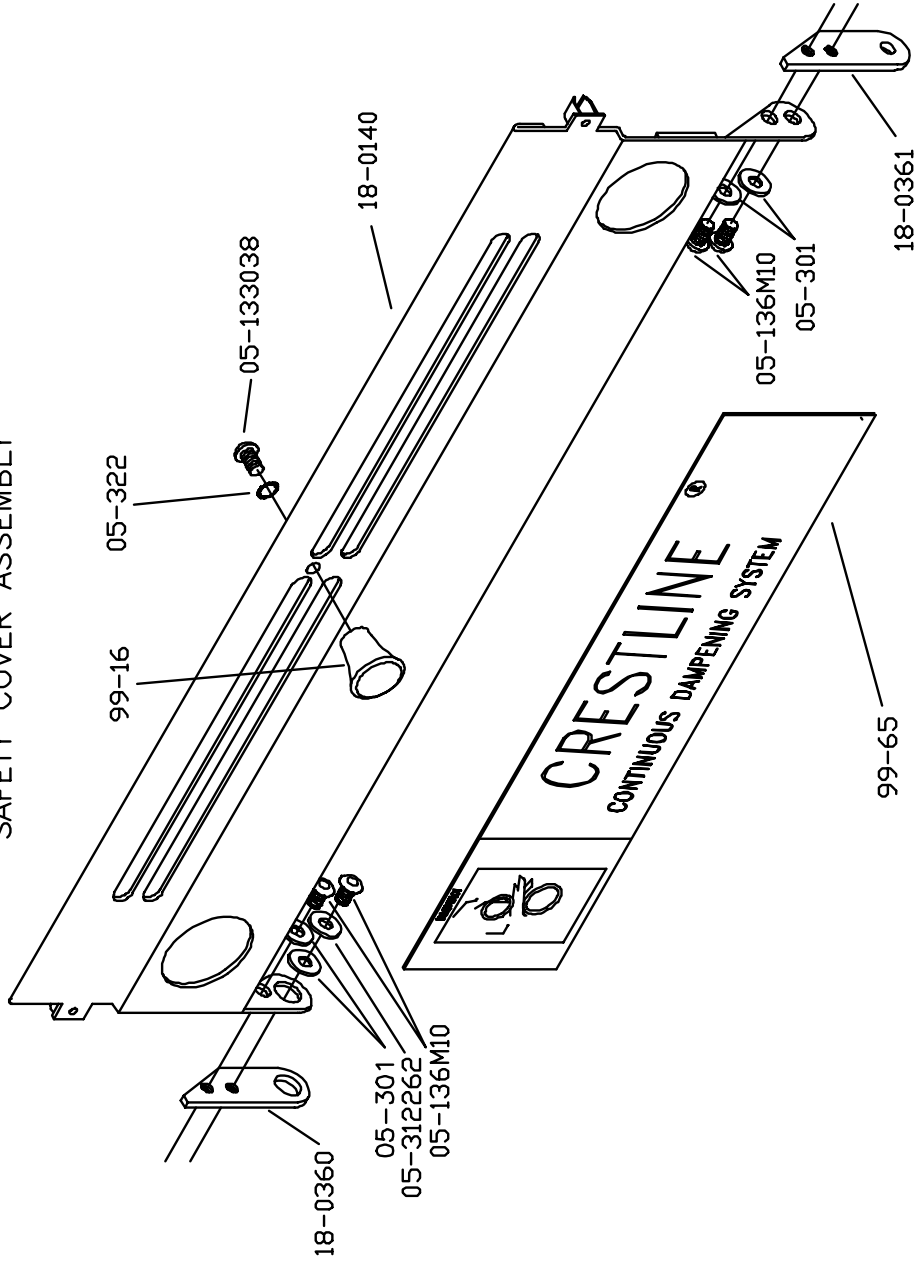



SIDE FRAME ASSEMBLY OPS  
 HAMADA RS/VS 34 INTEGRATED SATELLITE

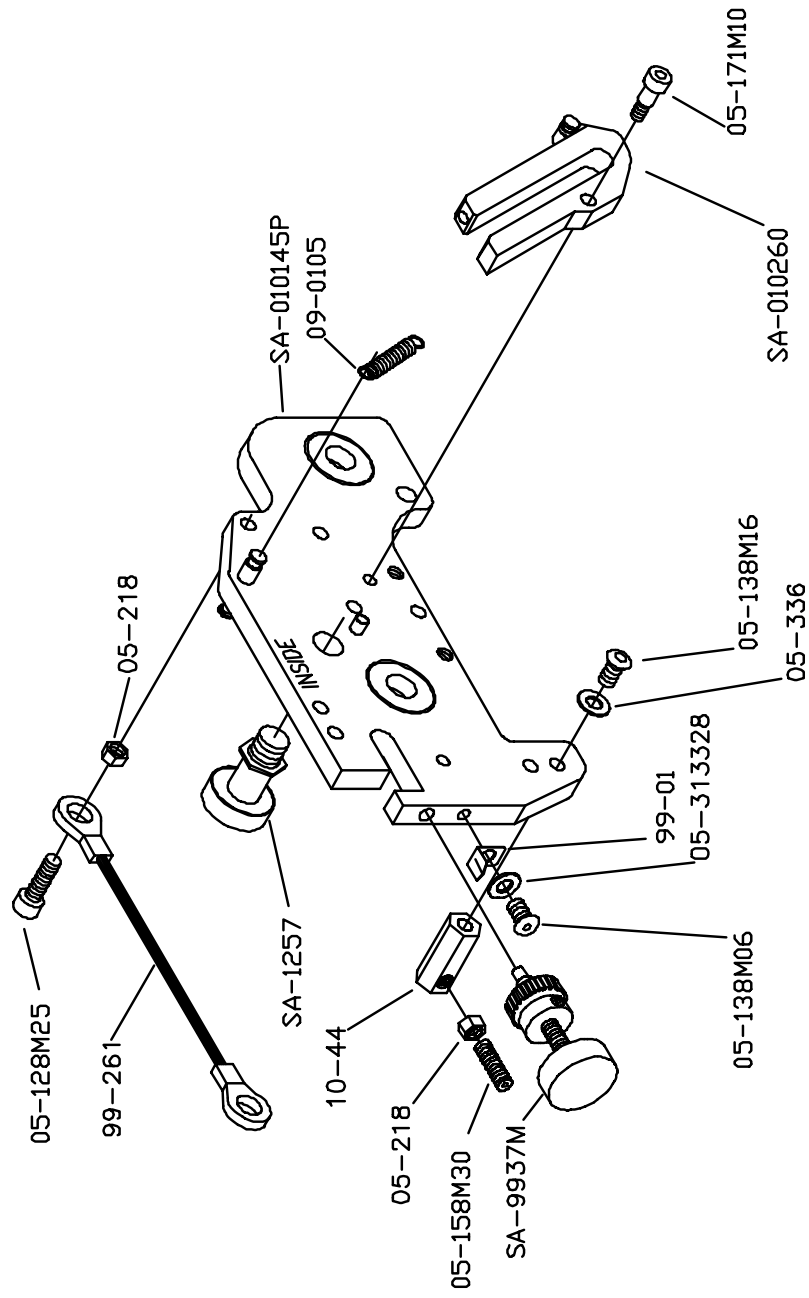

34NSC03, 3-28-97

SIDE FRAME ASSEMBLY NOPS  
 HAMADA RS/VS 34 INTEGRATED SATELLITE

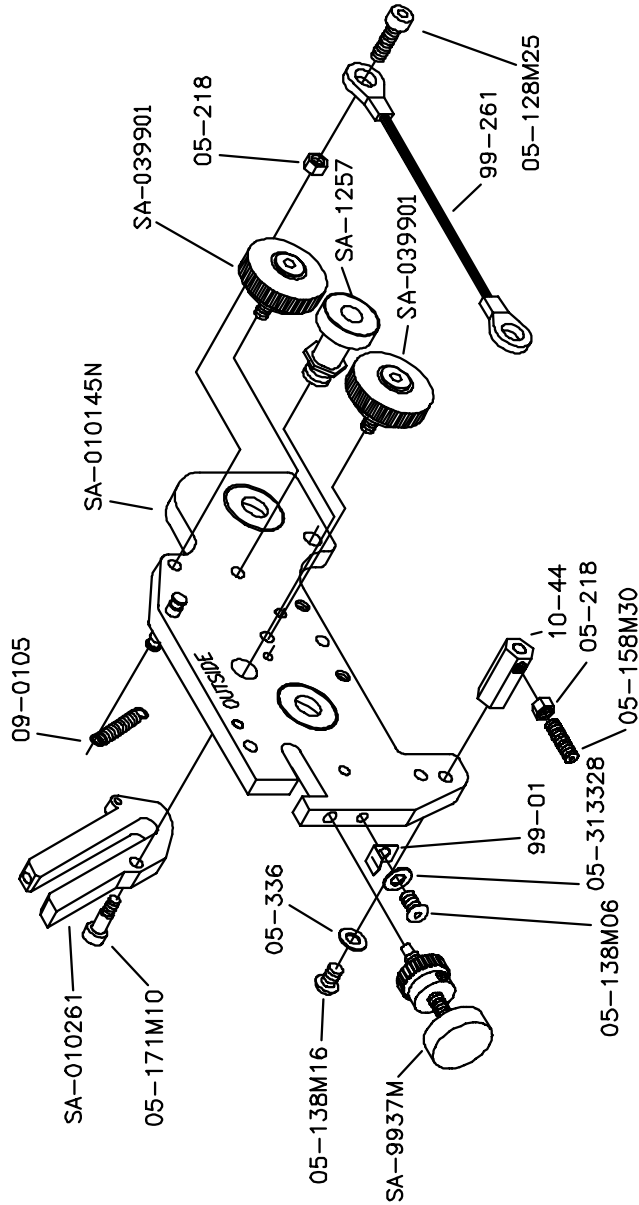

LIFT SHAFT ASSEMBLY  
 HAMADA RS/VIS 34 INTEGRATED SATELLITE

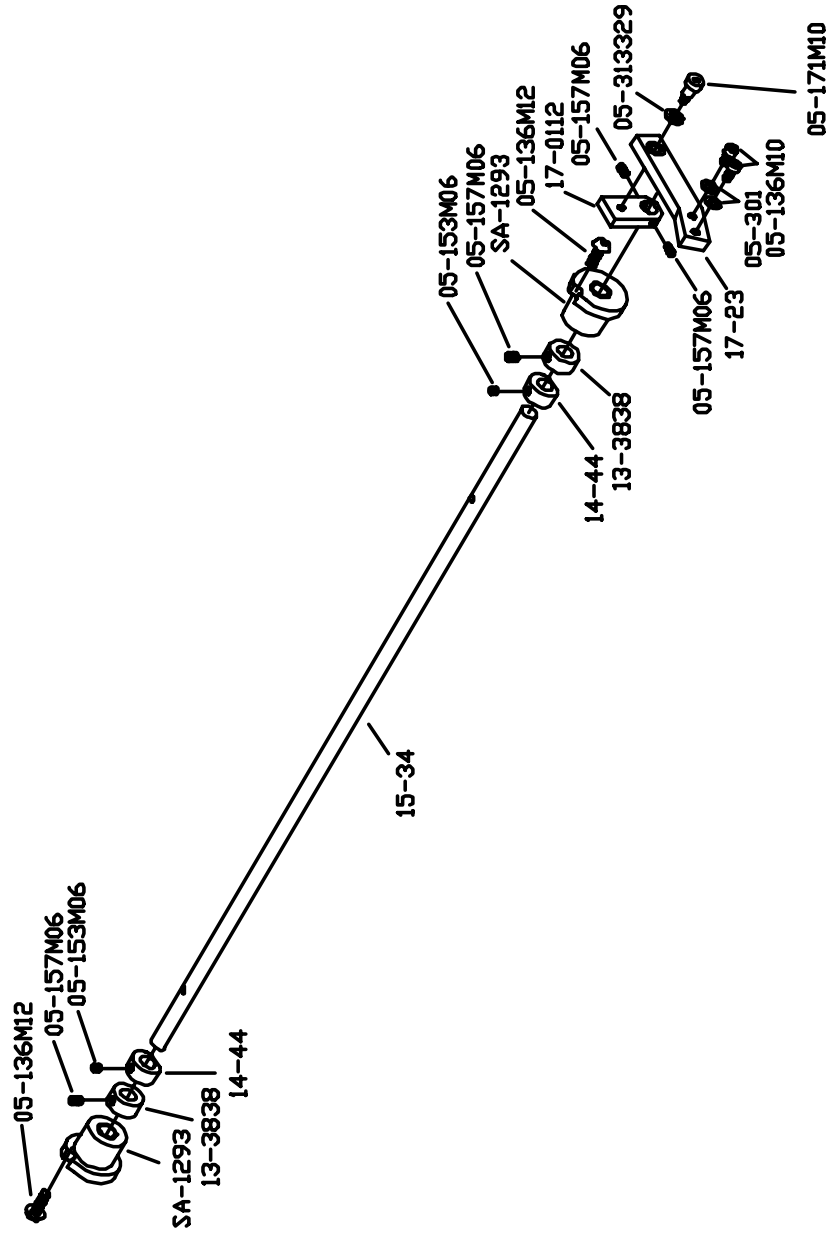

34NSC05, 6-97

DAMDENER LIFT MECHANISM  
HAMADA RS/V5 34 SATELLITE INTEGRATED

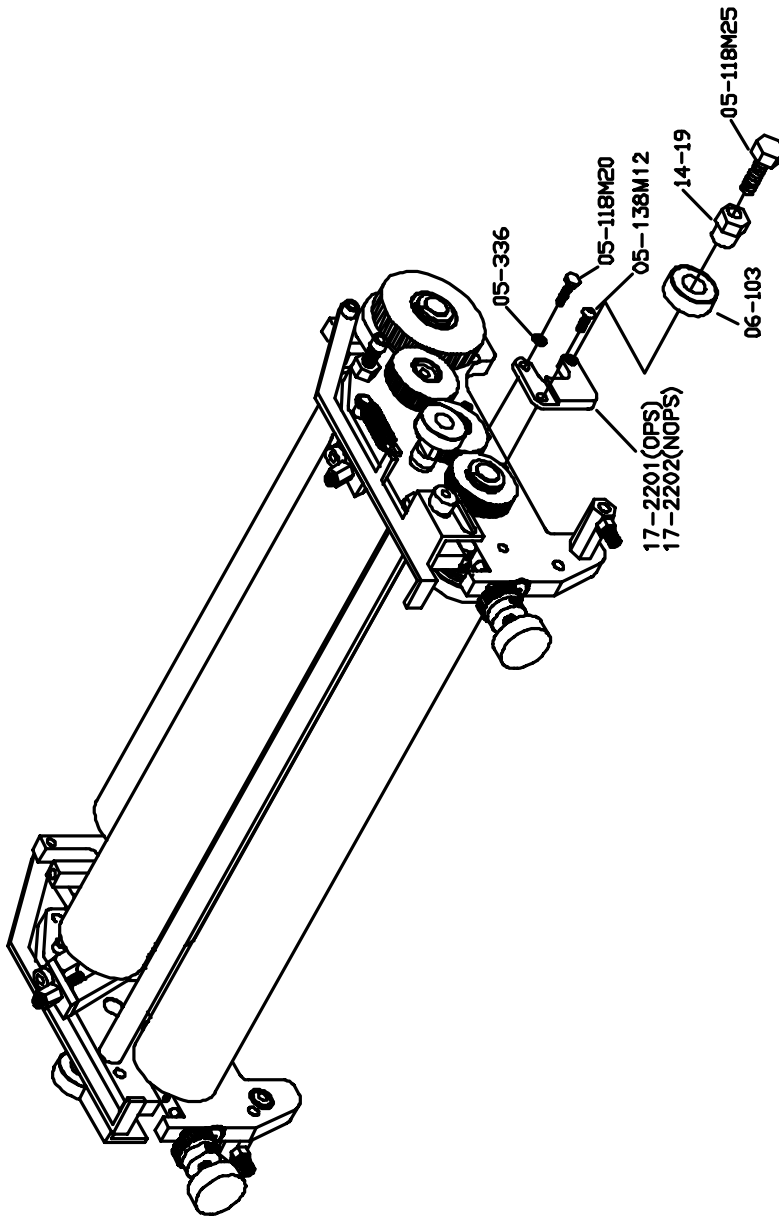

MOUNTING FRAME ASSEMBLY  
 HAMADA RS/VS 34 INTEGRATED SATELLITE

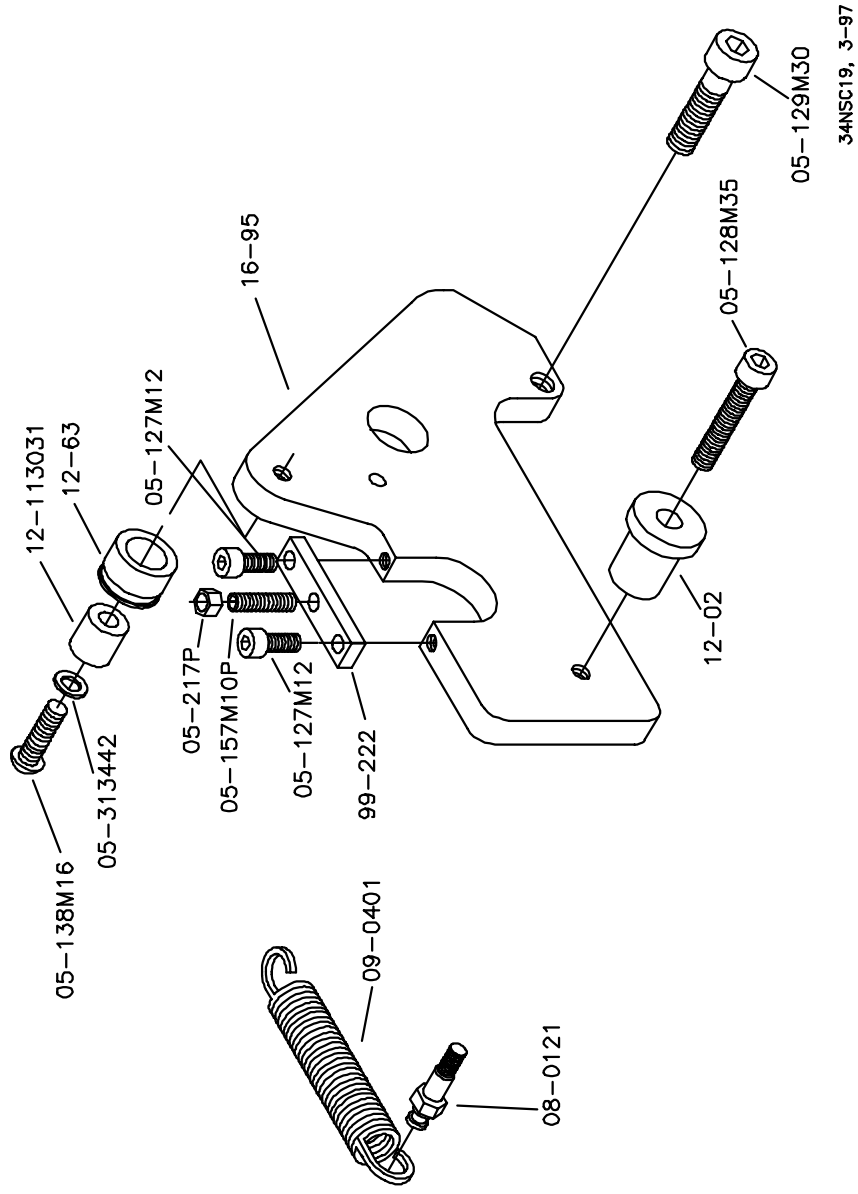

MOUNTING FRAME ASSEMBLY  
HAMADA RS/VIS 34 INTEGRATED SATELLITE

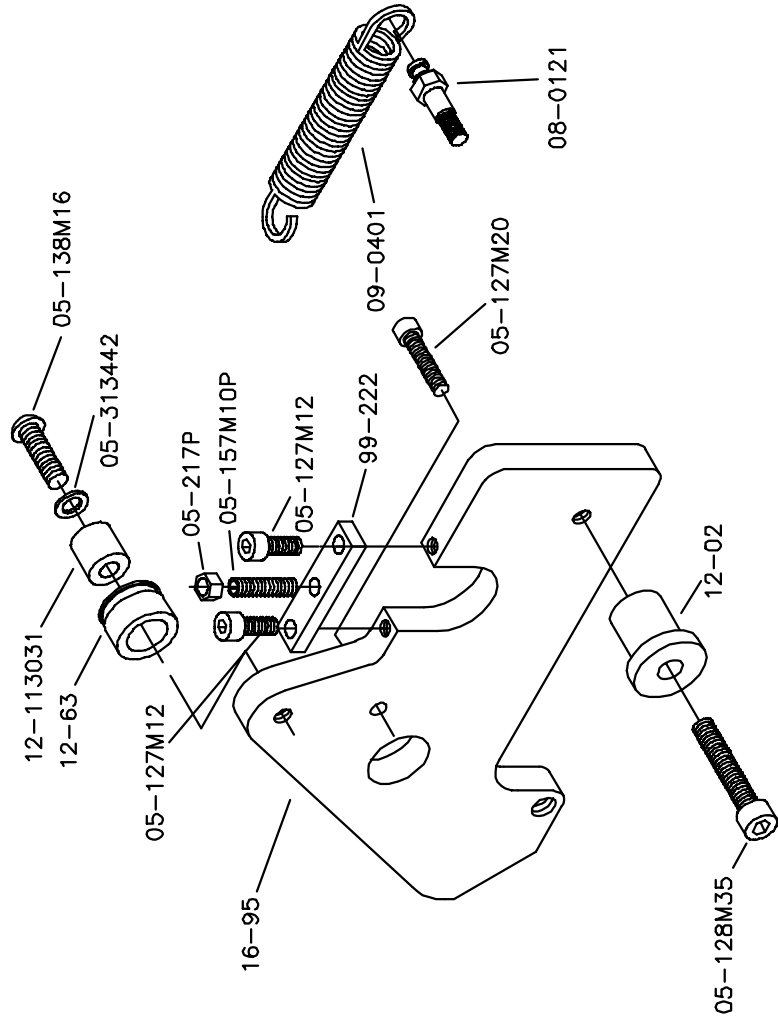

INTERMEDIATE/METERING ROLLERS  
HAMADA RS/VS 34 SATELLITE

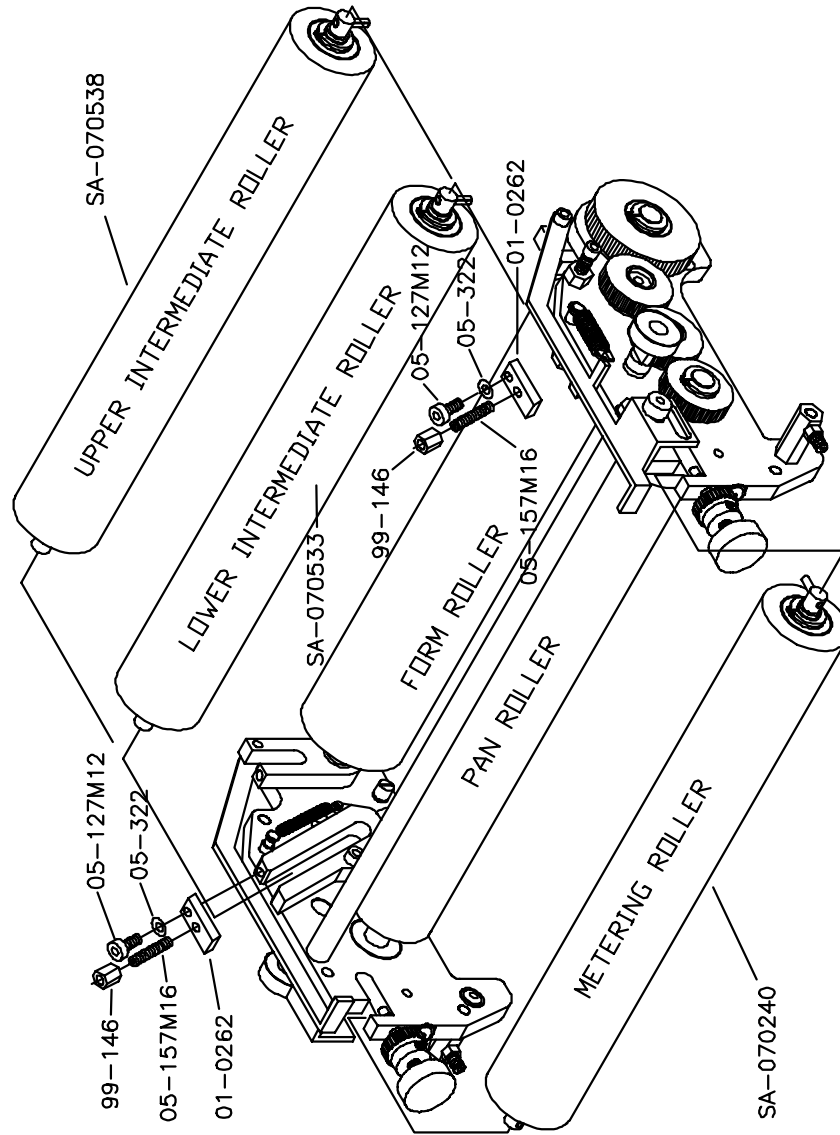

RS34SC04, 3-19-97

BRIDGE ROLLER ARM ASSEMBLY— NOPS  
HAMADA RS/VS 34 SATELLITE

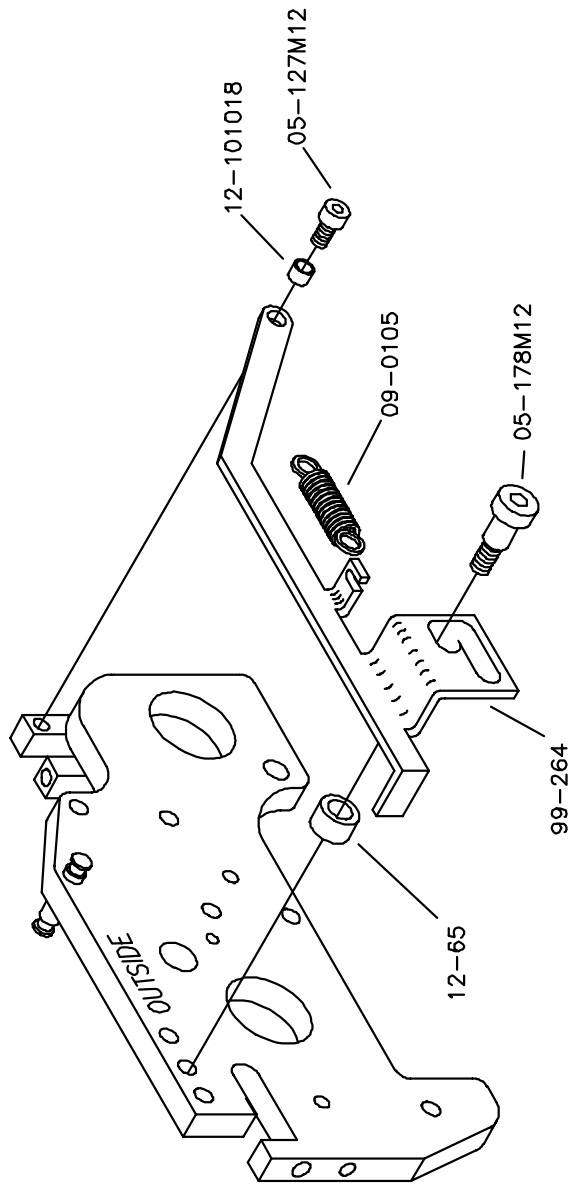



BRIDGE ROLL ARM ASSEMBLY-OPS  
HAMADA RS/VS 34 SATELLITE

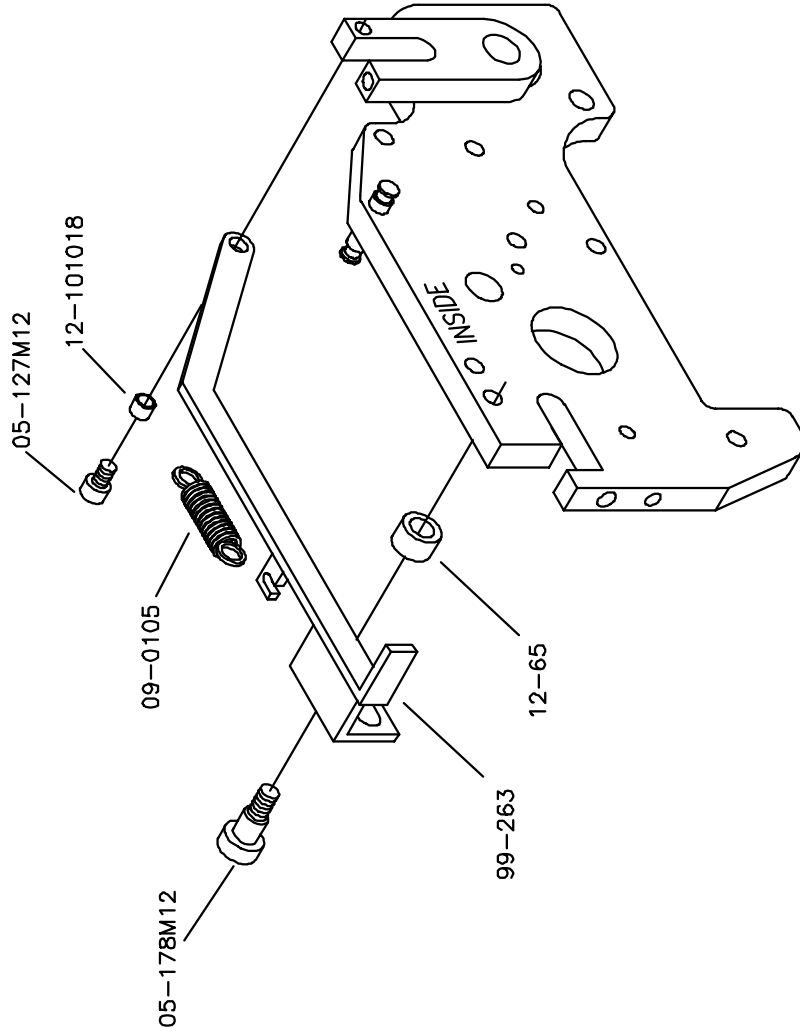

RS34SC06, 3-19-97

WATER PAN ASSEMBLY  
HAMADA RS/VS 34 SATELLITE

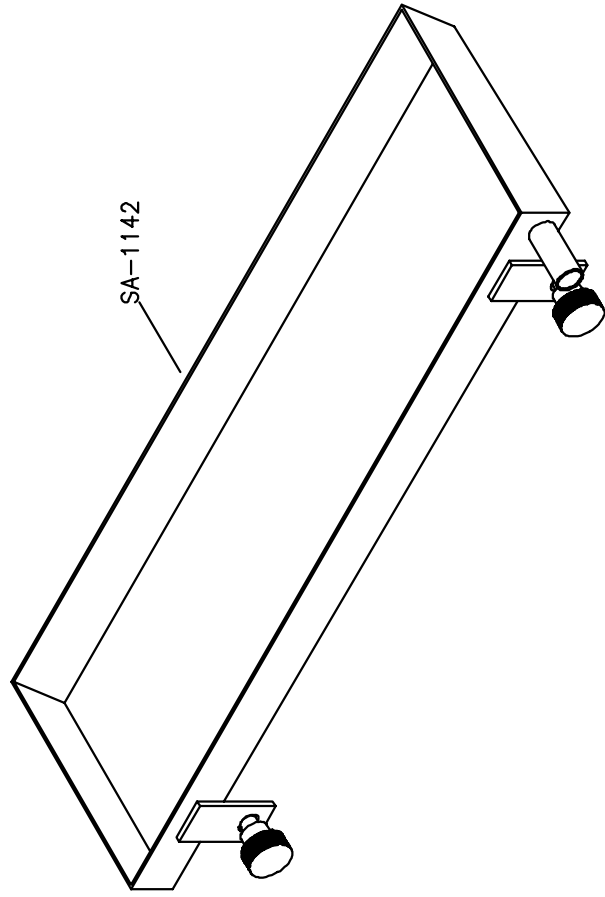

RS34SC11, 3-19-97

TIE BAR ASSEMBLY  
HAMADA RS/VS 34 INTEGRATED SATELLITE

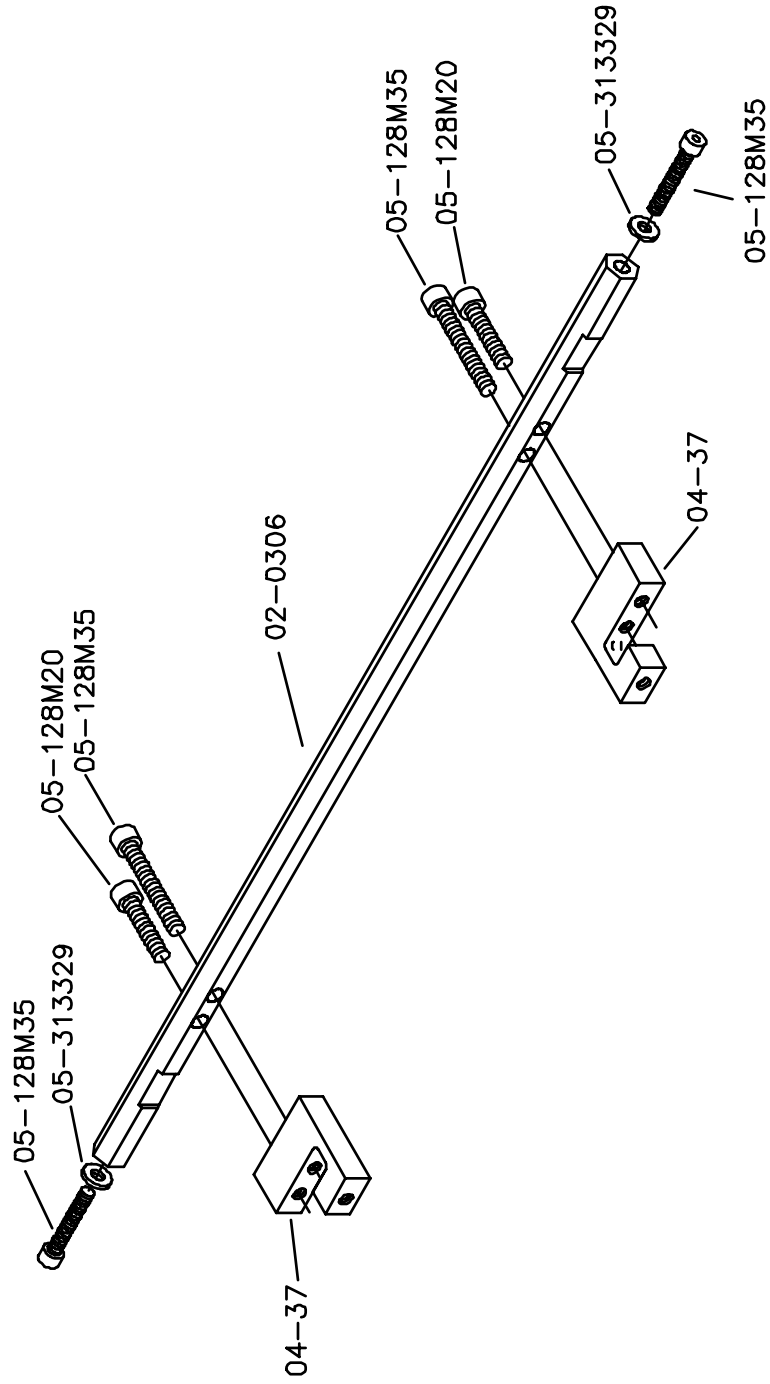

RS34SC13, 6-20-97

MISCELLANEOUS PARTS  
HAMADA RS/VS 34 INTEGRATED SATELLITE

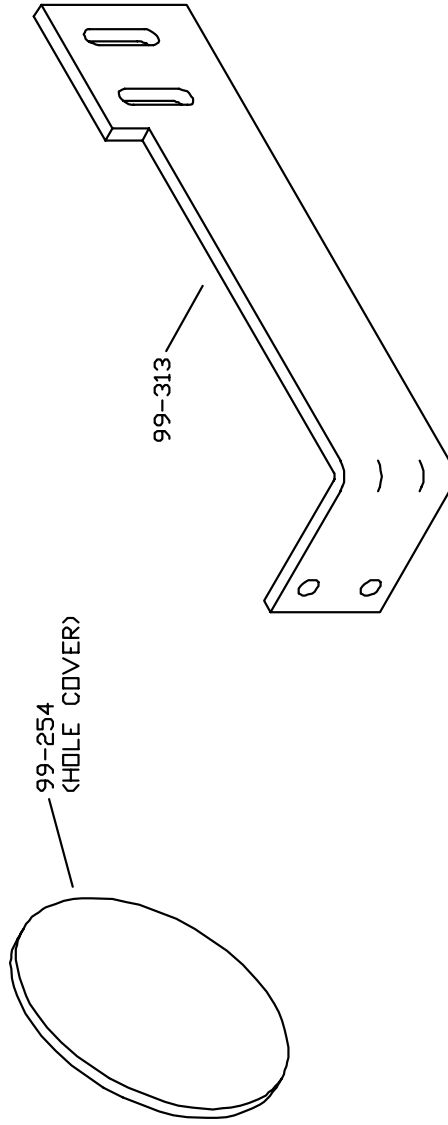





*A Pamarco Technologies Inc. Company*

11103 Indian Trail, Dallas, TX 75229 Phone 972-484-6808, Fax 800-365-6510  
E-mail [info@accel-us.com](mailto:info@accel-us.com), Web Site [www.accel-us.com](http://www.accel-us.com)